



**GMC**  
APPROVED  
ACCESSORIES

1956  
*Accessories  
Catalogue*



GMC TRUCK and COACH DIVISION  
GENERAL MOTORS CORPORATION  
PARTS and ACCESSORIES MERCHANDISING DEPARTMENT

# FOREWORD

The GMC Accessories Catalogue for 1956 will provide GMC Dealers and their personnel with complete and comprehensive information for use in selling Accessories to their customers. It is recommended that GMC Dealer sales personnel study, and become thoroughly familiar with the GMC Accessories and their application.

Many Accessories are required by state, local and I.C.C. Regulations and GMC Factory Approved Accessories meet requirements for compliance. Complete knowledge of their outstanding features is the key to successful selling of these useful accessories.

GMC offers a wide range of functionally designed Factory Approved Accessories that add comfort, convenience and safety to driving. Every new truck buyer is an individual accessories market. His best interests are served when you sell him the accessories styled for his GMC truck and designed to meet his specific requirements.

GMC Factory Approved Accessories are packaged complete with all necessary installation parts along with instruction sheets and templates wherever necessary.

This Catalogue will prove an invaluable tool for selling GMC Accessories . . . keep it handy and refer to it often.

GMC TRUCK & COACH DIVISION

GENERAL MOTORS CORPORATION

# INDEX



**PARTS and ACCESSORIES  
MERCHANDISING  
DATA**

MARCH, 1956

Description	Page	Description	Page
Retail Price Reference.....	1-2	Lighter—Cigarette.....	25
Replacement Parts Reference.....	3-4	Lights—Streamlined.....	26
Accessories—Junction Block....	5	Lights—Marker.....	27
Bumpers.....	6	Lights—Spot with Mirror.....	28
Brake—power.....	7	Light—R.H. Scoop & Tail.....	29
Clock.....	8	Lights—Stop—7 inch.....	30
Compass.....	9	Mirror—Inside R.V.....	31
Control Kit—Tractor Breakaway	10	Mirror—Fender.....	32
Cushion—Air Cooled.....	11	Mirrors—Rear View.....	33
Extinguisher—Fire.....	12	Mirrors—Outside.....	34
Filter—Gasoline.....	13	Mirrors—Outside—Bus Type... 35	
Flares—Flags, Fuses.....	14	Ornament—Hood.....	36
Guard—Grille Brush Type....	15	Radio—Antenna.....	37
Heaters—Defrosters, GMC....	16	Resin Repair Kit.....	38
Heaters—heavy duty.....	17	Rest—Arm.....	39
Heaters—deluxe Air-flow— and defroster.....	18	Seat—Bostrom Level Ride....	40
Heaters—economy, and defroster.....	19	Signal—Arm.....	41
Hooks—Pins—Towing.....	20	Signals—Directional.....	42
Horn—Air.....	21	Springs—Auxiliary.....	43
Hose Tanno.....	22	Tachometer.....	44
Jacks—hydraulic.....	23	Visor—R.H. Inside.....	45
Lamp—Courtesy.....	24	Visor—Outside and Viewer....	46
		Washer—windshield.....	47
		Lacquer—Self Spraying.....	48

# retail price reference

The following Accessories Price reference is furnished for your Merchandising convenience only. ALWAYS refer to Master Parts Price List for Price Information.

DESCRIPTION	Part No.	List Price	Recommended Installation Time (Hrs.)		Installed Price
			Cars.	COE	
Accessories Junction Block	2233646	\$ 3.25	.3	.3	_____
Brake, Vacuum Hydraulic, Power	2233499	35.00	1.5		_____
Bumper, Rear Chrome	2233511	28.00	.8		_____
Bumper, Rear Channel	2233570	18.95	.8		_____
Bumper, Rear Channel with Hitch Plate	2233571	23.25	.8		_____
License Plate Support and Lamp Kit—12 Volt	2233513	1.95	.4		_____
Case, Fuse & Flag	2233070	1.95			_____
Clock, Electric Wind—12 Volt	2233561	17.50	.3	.3	_____
Compass, Illuminated	2233653	5.95	H.R.	H.R.	_____
Cushion, Air Cooled Seat King Size	2233527	4.40			_____
Filter, Gasoline 3/4"	2233092	2.65	.4	.4	_____
Extinguisher, Fire 1 Quart	2233456	15.65			_____
Extinguisher, Fire 1 1/2 Quart	2233457	17.90			_____
Fluid, Fire Extinguisher 1 Quart	2233458	1.70			_____
Flare, Oil (Set of 3 in Brkt.)	2233073	11.65			_____
Flare, Oil (Set of 3 in Case)	2233074	12.90			_____
Flare, Reflector (Set of 3)	2233033	13.00			_____
Flare, Reflector (Set of 3)	2233294	9.20			_____
Fuses, 30 Minute	2233071	.40			_____
Fuses, 15 Minute	2233442	.36			_____
Flag and Shaft 15" x 17"	2233069	.65			_____
Flag Kit	2233337	2.60			_____
Guard, Door Edge (Pair)	2233544	3.45	.2	.2	_____
Guard, Grille Brush	2233614	32.00	1.5		_____
Guard, Grille Brush	2233616	32.00	1.0		_____
Handle, Assist	2233628	2.95	.3	.3	_____
Heater & Defroster, Economy Recirculating—12 Volt	2233515	43.50	1.8	1.8	_____
Heater & Defroster, Deluxe Air Flow—12 Volt	2233517	68.50	2.3	2.3	_____
Heater & Defroster, Heavy Duty Air Flow—12 Volt	2233371	106.25	3.3	3.3	_____
Hose-Tenna	2233657	9.95	H.R.	H.R.	_____
Holder, Air Hose End	2233658	1.75	H.R.	H.R.	_____
Holder, Vacuum Hose End	2233659	2.25	H.R.	H.R.	_____
Hooks, Tow Front (Pair)	2233504	8.75	.4	.4	_____
Hooks, Tow Rear (Pair)	2233508	9.50	H.R.	H.R.	_____
Installation Kit, Front Tow Hooks	2233506	3.25	.6		_____
Pins, Tow Front (Pair)	2233363	6.75	.4	.4	_____
Horn, Dual Air Chrome	2233575	35.00	2.2	2.2	_____
Jack, Hydraulic 3 Ton	2233037	21.70			_____
Jack, Hydraulic 5 Ton	2233038	25.20			_____
Jack, Hydraulic 8 Ton	2233039	28.80			_____
Jack, Hydraulic 12 Ton	2233040	39.10			_____
Lamp, Courtesy (Pair)	2233634	4.50	.9	.9	_____
Light, Armored Clearance/Marker Amber—12 Volt	2233483	1.48	H.R.	H.R.	_____
Light, Armored Clearance/Marker Red—12 Volt	2233484	1.48	H.R.	H.R.	_____
Light, Bee Hive Clearance/Marker Amber—12 Volt	2233486	.80	H.R.	H.R.	_____
Light, Bee Hive Clearance/Marker Red—12 Volt	2233488	.80	H.R.	H.R.	_____
Light, Flush Mtg. Clearance/Marker Amber—12 Volt	2233490	1.20	H.R.	H.R.	_____
Light, Flush Mtg. Clearance/Marker Red—12 Volt	2233492	1.20	H.R.	H.R.	_____
Light, Hinged Brkt. Clearance/Marker Red—12 Volt	2233494	1.25	H.R.	H.R.	_____
Light, R.H. Stop & Tail—12 Volt	2233639	7.60	.5	.5	_____
Light, Stop 7"—12 Volt	2233496	5.60	.5	.5	_____



FIT RIGHT—LAST LONGER—WITH THE EXTRA MARGIN OF SAFETY BUILT IN

# retail price reference

DESCRIPTION	Part No.	List Price	Recommended Installation Time (Hrs.)		Installed Price
			Conv.	COE	
Light, Streamlined Marker—12 Volt (100-670 Conv. F350-F600 COE) . . .	2233521	\$ 2.00	.8	.8	_____
Light, Streamlined Marker—12 Volt (900-970 Conv. F620-F950 COE) . . .	2233521	2.00	1.6	1.6	_____
Light, Streamlined Marker—Chrome 12 Volt (100-670 Conv. F350-F600 COE) . . . . .	2233525	2.90	.8	.8	_____
Light, Streamlined Marker—Chrome 12 Volt (900-970 Conv. F620-F950 COE) . . . . .	2233525	2.90	1.6	1.6	_____
Light, Spot W/Mirror—12 Volt . . . . .	2233585	22.50	1.1	1.1	_____
Lighter, Cigarette Illuminated—12 Volt . . . . .	2233470	3.50	.3	.3	_____
Mirror, Fender . . . . .	2233376	5.00	.4	.4	_____
Mirror, Inside Glare Proof . . . . .	2233509	3.95	.2	.2	_____
Bracket, 1/3 Mirror Mounting . . . . .	2233655	1.55	.2	.2	_____
Mirror, Bus Type (Pair) . . . . .	2233455	29.00	1.5	1.5	_____
Mirror, Bus Type (Pair) . . . . .	2233537	29.00	1.5	1.5	_____
Mirror, Bus Type (One) . . . . .	2233644	9.95	.7	.7	_____
Mirror, Fixed Type R.H. . . . .	2233551	3.75	.4	.4	_____
Mirror, R.H. Ext. Arm Round Head . . . . .	2233553	5.00	.5	.5	_____
Mirror, R.H. Ext. Arm Rectangular Head . . . . .	2233555	7.25	.5	.5	_____
Mirror, R.H. Ext. Arm Rectangular Head . . . . .	2233330	7.25	.5	.5	_____
Reinforcement, Door R.H. Mirror Mounting . . . . .	2233549	.75	.5	.5	_____
Brace, Mirror Arm . . . . .	2233267	3.01	.5	.5	_____
Head, Mirror Rectangular . . . . .	2233266	3.25	.2	.2	_____
Ornament, Hood . . . . .	2233348	11.50	.5	.5	_____
Radio—12 Volt . . . . .	2233480	62.25	1.0	1.0	_____
Antenna . . . . .	2233579	7.25	.5	.5	_____
Reflector, Amber . . . . .	2233134	.60	H.R.	H.R.	_____
Reflector, Red . . . . .	2233133	.60	H.R.	H.R.	_____
Reflex and Bracket . . . . .	2233420	1.25	.2	.2	_____
Resin Repair Kit . . . . .	2233617		H.R.	H.R.	_____
Rest Arm, Blue . . . . .	2233460	3.90	.3	.3	_____
Rest Arm, Green . . . . .	2233462	3.90	.3	.3	_____
Rest Arm, Brown . . . . .	2233464	3.90	.3	.3	_____
Rest Arm, Gray . . . . .	2233466	3.90	.3	.3	_____
Seat, Level Side 80 . . . . .	2233590	86.95		1.0	_____
Seat, Level Side 80 . . . . .	2233591	86.95	1.0	1.0	_____
Seat, Companion . . . . .	2233592	45.00	.3	.3	_____
Shield, Door Handle (Pair) . . . . .	2233546	2.95	.2	.2	_____
Signal, Directional Frt. W/Switch Class "A"—12 V. . . . .	2233652	17.20	1.3	1.7	_____
Signal, Directional Frt. & Rear W/Switch Class "B"—12 Volt . . . . .	2233650	19.50	.8		_____
Signal, Illuminated Arm—12 Volt . . . . .	2233641	13.50	H.R.	H.R.	_____
Springs, Aux. Single Leaf . . . . .	2233450	24.50	1.0		_____
Springs, Aux. Multiple Leaf . . . . .	2233581	32.75	1.3		_____
Springs, Aux. Multiple Leaf . . . . .	2233589	36.95	1.3		_____
Tachometer, Electric—12 Volt . . . . .	2233600	42.95	.5		_____
Tachometer, Electric—12 Volt . . . . .	2233648	42.95	.5		_____
Visor, Sun R.H. . . . .	2233474	3.25	.3	.3	_____
Visor, Sun Outside . . . . .	2233594	14.90	1.0	1.0	_____
Viewer, Traffic Light . . . . .	2233612	4.85			_____
Tractor Breakaway Control Kit . . . . .	2233384	37.50	H.R.	H.R.	_____
Washer, Windshield . . . . .	2233573	6.75	.6	.6	_____
Solvent & Anti-Freeze W/5 Washer . . . . .	2233472	.60			_____
Lacquer, Self Spraying, All Colors . . . . .	See Page 48	2.25	H.R.	H.R.	_____

FOR A NEW THRILL DRIVE A GMC TRUCK HYDRAMATIC



# replacement parts for accessories

## BUMPER, Rear Chrome ..... 2233511

Group No.	Part No.	Description
22.0250	3714646	Bar, Face
22.0260	3716061	Bracket, Inner L.H.
22.0260	3716062	Bracket, Inner R.H.
22.0260	3716063	Bracket, Outer L.H.
22.0260	3716064	Bracket, Outer R.H.

## BUMPER, Rear Channel ..... 2233570-571

22.0260	2237001	Bracket, Inner R.H. & Outer L.H.
22.0260	2237002	Bracket, Inner L.H. & Outer R.H.

## FILTER, Gasoline ..... 2233092

22.0470	2218832	Bowl
22.0480	2218834	Bowl
22.0490	2218835	Gasket
13.0960	5451951	Nipple

## GRILLE GUARD, Brush Type ..... 2233614

22.0630	2237632	Brace, Grille Guard (2 Req'd)
---------	---------	-------------------------------

## GRILLE GUARD, Brush Type ..... 2233616

22.0630	2237258	Brace, Grille Guard R.H.
22.0630	2237257	Brace, Grille Guard L.H.

## HEATER & DEFROSTER, Air Flow H.D. 12 Volt ... 2233571

22.0670	3113429	Bracket, Double Hose Support
22.0690	3124143	Core
22.0720	3128928	Fan
22.0740	3124138	Hose 4" ID x 18"
22.0780	5047690	Motor
22.0790	3131873	Control Panel, Dash
22.0800	3131861	Panel, W/S Defroster R.H.
22.0800	3124213	Panel, W/S Defroster L.H.
22.0810	3132028	Switch
22.0820	3131868	Valve, Heat Distributor
22.0830	3129280	Valve, Temperature Control

## HEATER & DEFROSTER, Economy Recirculating 12 Volt ..... 2233515

22.0690	3134580	Core
22.0720	3122011	Fan
22.0750	3134561	Inlet R.H.
22.0750	3134291	Inlet L.H.
22.0760	7265766	Knob, Switch
22.0780	5047849	Motor
22.0810	3715372	Switch

## HEATER & DEFROSTER, Air Flow 12 Volt ..... 2233517

Group No.	Part No.	Description
22.0680	3134216	Cable Assy., Air Inlet Valve
22.0680	3134741	Cable Assy., Defroster & Temp. Control
22.0690	3135271	Core
22.0710	3135947	Face, Heater Control, Chrome
22.0720	3134895	Fan
22.0750	3134561	Inlet R.H.
22.0750	3134291	Inlet L.H.
22.0780	5047798	Motor
22.0810	3134242	Switch
22.0820	3134209	Valve, Temperature Control
22.0740	3134837	Hose, Formed Valve to Core

## HOSE, Heater 25 Foot Roll (22.0740) ..... 2224576

## HOSE, Defroster 1 1/2" ID x 36" (22.0720) ..... 3112941

## HOSE, Defroster 2" ID x 36" (22.0730) ..... 3125764

## HORN, Dual Air, Chrome ..... 2233575

22.0920	2113064	Valve
---------	---------	-------

## LIGHTER, Cigarette 12 Volt ..... 2233470

22.1260	3710581	Element
---------	---------	---------

## LIGHT, Amber Streamlined ..... 2233519-521 2233523-525

22.1080	2178675	Lens
22.1060	1423003	Bulb 3 CP 6 Volt No. 63
22.1060	142450	Bulb 3 CP 12 Volt No. 67

## LIGHT, Armored ..... 2233482-484 2233529-531

22.1080	2245895	Lens, Amber
22.1080	2245894	Lens, Red
22.1060	1423003	Bulb 3 CP 6 Volt No. 63
22.1060	142450	Bulb 3 CP 12 Volt No. 67

## LIGHT, Bee Hive ..... 2233143-144-145 2233486-488-494

22.1080	2213817	Lens, Amber
22.1080	2213816	Lens, Red
22.1070	2213818	Gasket
22.1060	1423003	Bulb 3 CP 6 Volt No. 63
22.1060	142450	Bulb 3 CP 12 Volt No. 67



FIT RIGHT—LAST LONGER—WITH THE EXTRA MARGIN OF SAFETY BUILT IN

# replacement parts for accessories

## LIGHT, Flush ..... 2233146-147 2233490-493

Group No.	Part No.	Description
22.1080	2253457	Lens, Amber
22.1080	2253458	Lens, Red
22.1060	125588	Bulb 2 CP 6 Volt No. 55
22.1060	127934	Bulb 2 CP 12 Volt No. 57

## LIGHT, Spot W/Mirror ..... 2233585

22.1140	273227	Sealed Beam 12 Volt
22.1130	5946367	Mirror

## LIGHT, Stop & Tail R.H. .... 2233639

22.1230	5947580	Lens, Lamp
22.1220	914301	Gasket, Lens
22.1210	5947626	Door, Lamp
22.1190	454645	Bulb 21 & 3 CP 12 Volt
22.1200	2309821	Bracket (Flareless)
22.1200	3724002	Bracket (Pickup)
22.1200	3716708	Bracket (Frame)

## LIGHT, Stop 7" Red ..... 2233389-496

22.1230	2318444	Lens
---------	---------	------

## MIRROR, Fender ..... 2233376

22.1330	2318552	Head
---------	---------	------

## MIRROR, R.H. Short Fixed ..... 2233551

22.1330	2696632	Head, Round 5" Dia.
22.1360	3720230	Screw, Mtg. (3 Req'd)

## MIRROR, R.H. Extension Arm ..... 2233553-555

22.1330	2696632	Head, Round 5" Dia.
22.1330	2733266	Head, Rect. 5" x 9"
22.1310	3717450	Lower Mtg. Bracket
22.1310	2331599	Upper Mtg. Bracket
22.1290	2275315	Arm Assy., Extension
22.1320	2311361	Glass Only 5" x 9"
22.1360	3720230	Screw, Mtg. (3 Req'd)

## MIRROR, Rectangular R.H. .... 2233330

22.1330	2333266	Head 5" x 9" Rubber Rim
22.1310	2279194	Bracket, Casting R.H.
22.1320	2311361	Glass, Mirror

## MIRROR, Bus Type 6" x 16" ..... 2233455-557

22.1330	2325078	Glass Mirror
22.1330	2328003	Head 6" x 16"

## MIRROR, Bus Type 6" x 12" ..... 2233444

Group No.	Part No.	Description
22.1330	2350096	Glass Only 6" x 12"
22.1330	2350095	Head 6" x 12"

## BRACE, Mirror Arm ..... 2233367

22.1340	125992	Crimp Nut (2 Req'd)
---------	--------	---------------------

## RADIOS ..... All

Radio parts and service obtainable from  
United Motors Delco Electronic Service Stations

## REST, Arm ..... 2233460-2-4-6

22.1580	3716955	Base, Arm Rest
22.1600	3716953	Screw, Mounting

## SIGNAL, Direction Class "B" 12 Volt ..... 2233459

22.1790	2966140	Wiring Harness, Lamp
22.1790	2966149	Wiring Harness, Flasher
22.1730	3701580	Bracket, Flasher Mtg.
22.1770	5943797	Flasher Assy., 12 Volt
22.1880	897915	Switch Assy.
22.1750	5943818	Cancelling Cam, Switch
22.1860	5947669	Socket & Wire Assy., Parking Lamp
22.1740	454645	Bulb, Parking Lamp (30-4 C.P.) 12 Volt
22.1890	2963068	Wire Assy., Tail Lamp Ext.
22.1870	3724002	Support, Tail Lamp Bracket
22.1820	898248	Lamp Assy., Stop & Tail R.H.
22.1840	5945335	Lever Assy., Switch

## SIGNAL, Direction Class "A" 12 Volt ..... 2233452

22.1810	897532	Lamp, Fnt. Double Face 12 Volt
22.1830	5945911	Lens, Red
22.1830	5945910	Lens, Amber
22.1780	5944154	Gasket, Lens
22.1740	142456	Bulb 12 Volt 21 CP
22.1770	2343655	Flasher Assy., 12 Volt
22.1790	2966140	Wiring Harness Assy.
22.1790	2966149	Wire Assy.
22.1730	3701580	Bracket, Flasher Mtg.
22.1880	897911	Switch Assy.
22.1750	5943818	Cancelling Cam, Switch
22.1840	5945335	Lever Assy., Switch
22.1760	1455697	Connector, 3 in Line
22.1850	5941809	Reinforcement Plate, Fender

## WASHER, Windshield ..... 2233373

22.2080	2318443	Reservoir Assy., Plastic
---------	---------	--------------------------

FOR A NEW THRILL DRIVE A GMC TRUCK HYDRAMATIC



# junction block

## accessories

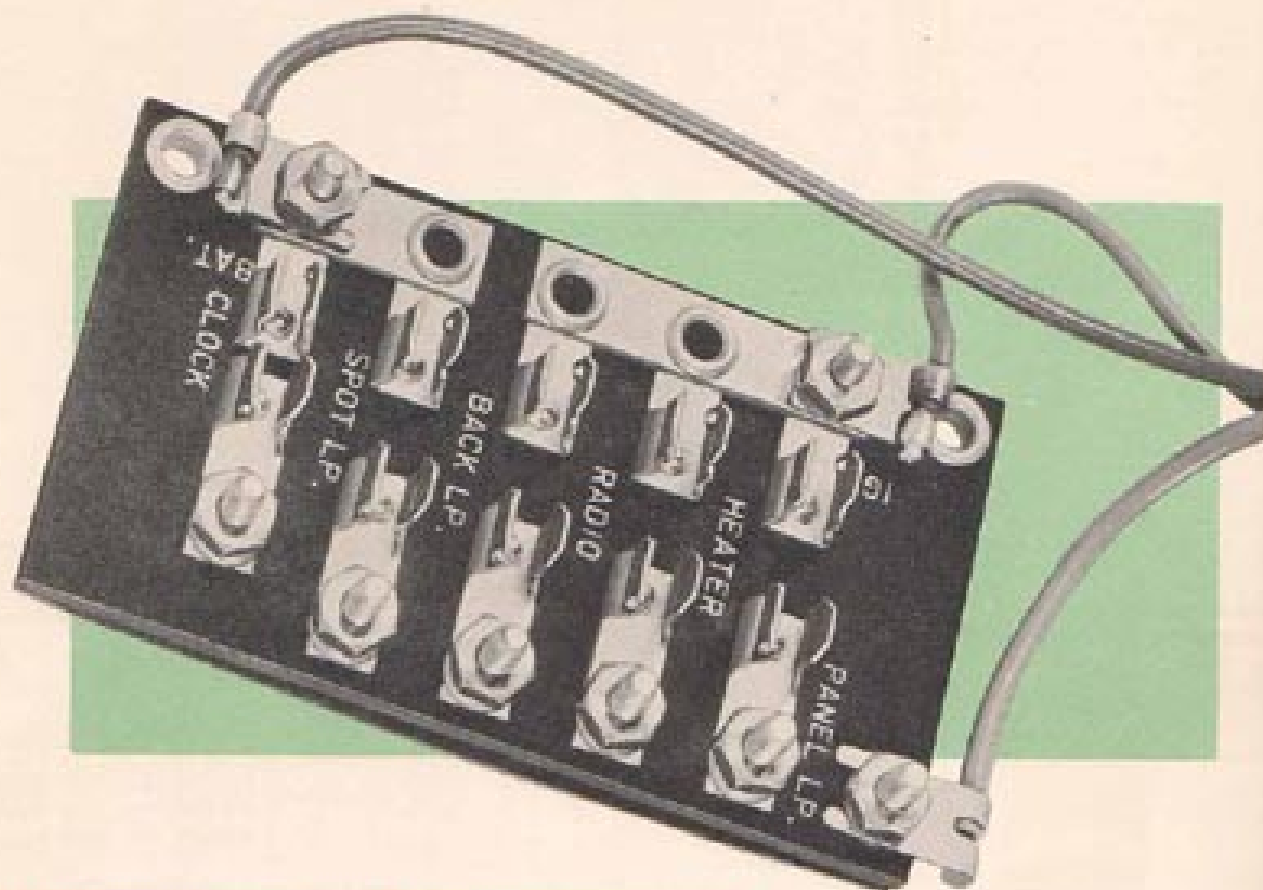

PART NO.	DESCRIPTION	MODEL APPLICATION
2233646	Accessories, Junction Block	100-670, F350-F600

### PRODUCT DATA

A compact fuse and junction block which simplifies accessories installation and provides a single, convenient location for fuses and terminals. Provides two constantly "Hot" terminals and three terminals which are "Hot" only when the ignition switch is in the *On* position. Eliminates splicing wires and overloading circuits.

The GMC Accessories Junction Block is recommended for use when installing radio, heater, spotlight, clock or

any other multiple accessory grouping.

GMC Accessories Junction Block is packaged complete with wiring harness, attaching parts and installation instruction sheet.

Factory installed as standard equipment on all 1956 models using electric shift 2 speed axles or low air warning device.



FIT RIGHT—LAST LONGER—WITH THE EXTRA MARGIN OF SAFETY BUILT IN

# rear bumpers



PART NO.	DESCRIPTION	MODEL APPLICATION
2233511	Bumper, Rear, Chrome	All 100 thru 250 Pickups
2233570	Bumper, Rear, Channel	All 100 thru 250 Pickups
2233571	Bumper, Rear, Channel W/Hitch Plate	All 100 thru 250 Pickups
2233513	License Plate Supp't. Kit 12 Volt	Required for any rear bumper installation

## PRODUCT DATA

GMC Rear Bumpers are available for installation on all GMC Pickups. Massive Chrome Wrap Around Bumpers to match the Front Bumper; or for Heavy Duty use, the rugged Channel type. Both are complete with face bar, mounting brackets, all necessary bolts, nuts, washers and complete instructions for installation.

License Plate Support Kit complete with license plate

illuminating lamp is also available for use in relocating license plate as required when installing rear bumper.

GMC Channel Bumpers, ribbed for added strength, are made of heavy 7 gauge hot rolled steel 67" x 6" with 1 1/4" rolled flange. Welded 30" hitch plate and attaching brackets of 1/4" x 2 1/4" steel assure strength and rigidity for heaviest loads.

FOR A NEW THRILL DRIVE A GMC TRUCK HYDRAMATIC





# power brake

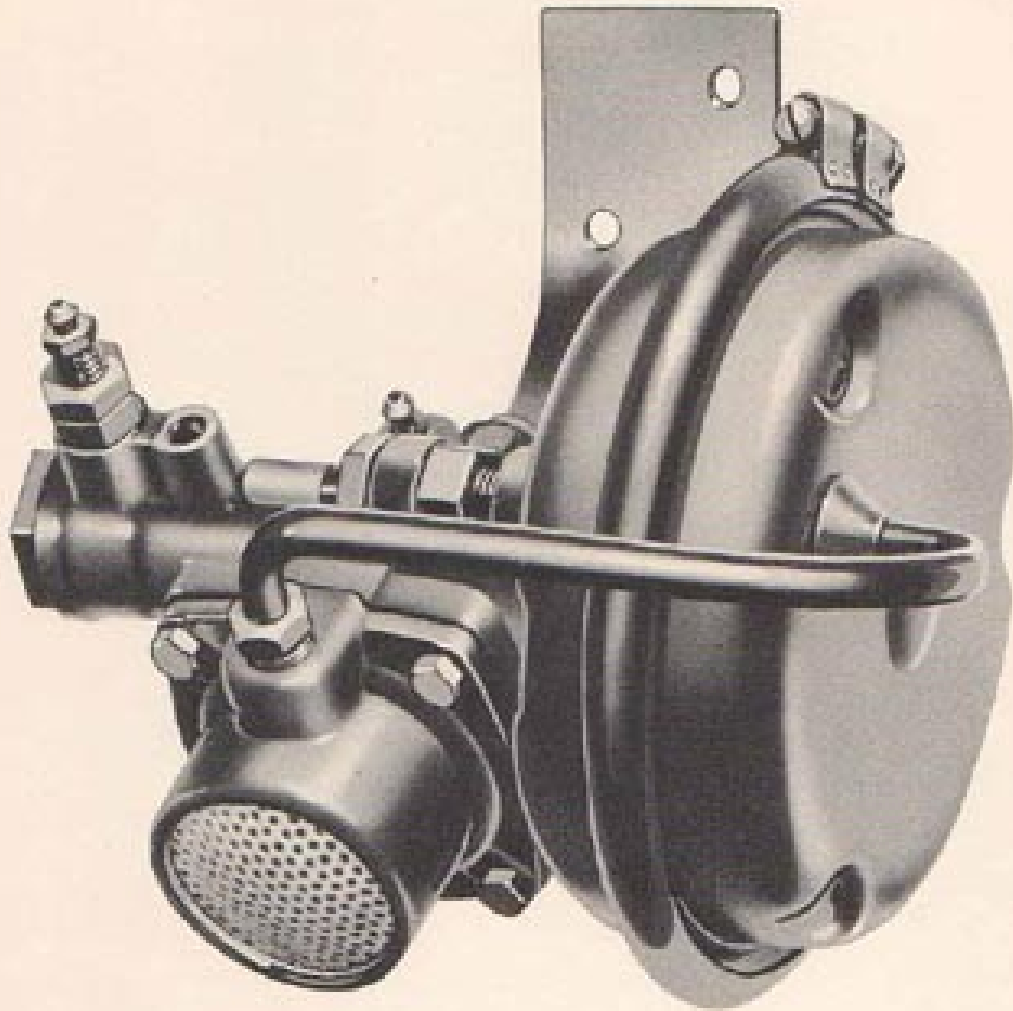

LRT NO.	DESCRIPTION	MODEL APPLICATION
233499	Power Brake, Vacuum-Hydraulic	100 thru 250, except PM 250

## PRODUCT DATA

For smooth, effortless stops with complete control and retention of "Brake Feel," the GMC Power Brake adds immeasurably to driving safety. Air tight, sealed for protection, it requires no lubrication nor adjustments.

The kit is complete with mounting bracket, all attaching parts including tubing with flared ends and connectors assembled. It utilizes the brake pedal and linkage already in the truck.



FIT RIGHT—LAST LONGER—WITH THE EXTRA MARGIN OF SAFETY BUILT IN

# auto-wind clock



PART NO.	DESCRIPTION	MODEL APPLICATION
3333561	Clock, Auto-Wind, Electric 12 Volt	All—except those equipped w/vacuum gauge or tachometer

## PRODUCT DATA

The GMC Truck Clock embodies a precision built, jeweled pin lever movement constructed to the highest horological standards. Electrically energized automatic wind mechanism eliminates the necessity of hand winding and the many undesirable characteristics common to the ordinary automotive clock, enabling the manufacturer to

issue a long term warranty on this superbly engineered timepiece. Manual hand set button and regulating arm provide ease of adjustment.

Designed to match the beautiful new instrument panel, this handsome clock with illuminated dial will add beauty and utility to every GMC Truck.

FOR A NEW THRILL DRIVE A GMC TRUCK HYDRAMATIC



# compass, illuminated

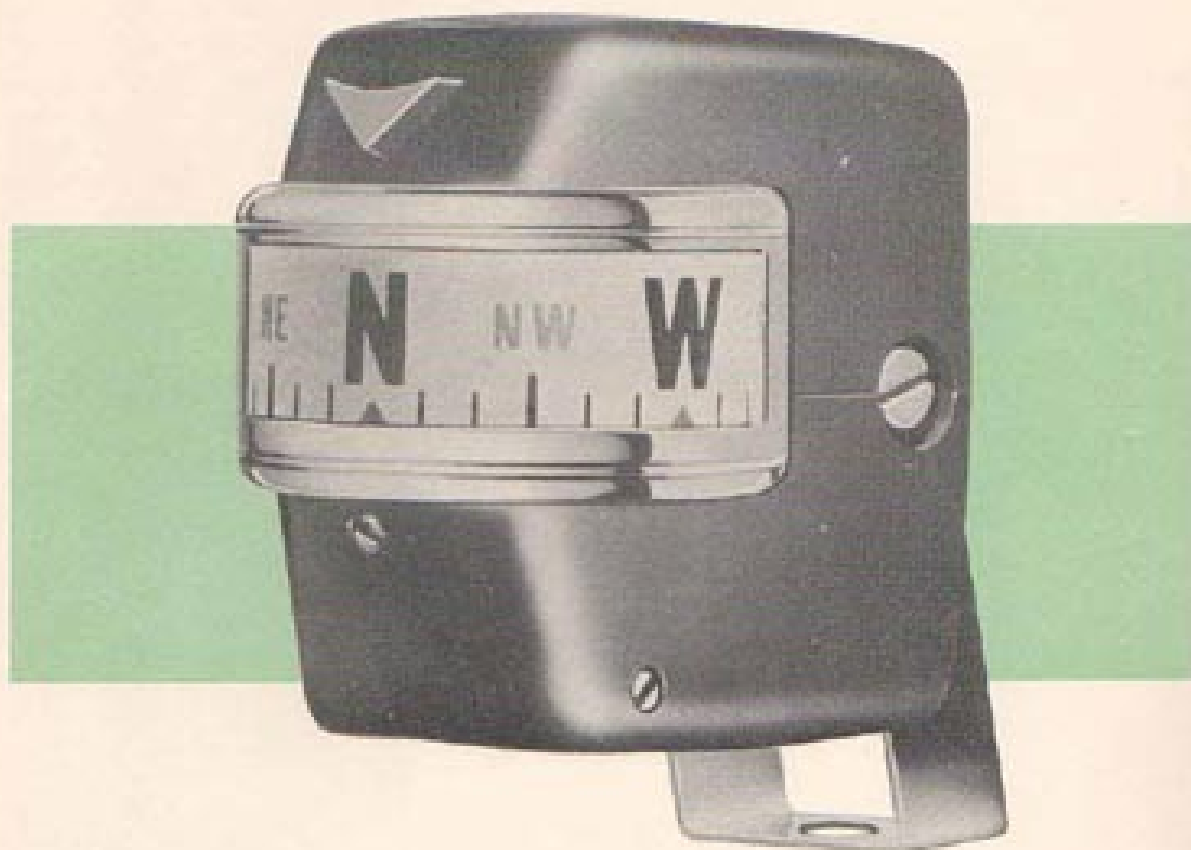

PART NO.	DESCRIPTION	MODEL APPLICATION
1233653	Compass, illuminated	All models

## PRODUCT DATA

The graceful lines of the GMC ILLUMINATED Compass harmonize with the attractive styling of the GMC Truck, and offer truck owners a truly useful and reliable accessory.

Hermetically sealed and fully jeweled, it is a precision

built instrument. The dial affords a wide angle of visibility and the large red and black letters are easy to read.

Two compensating screws are provided for micrometer adjustment, and a single wire system provides illumination for night use.



FIT RIGHT—LAST LONGER—WITH THE EXTRA MARGIN OF SAFETY BUILT IN

# tractor breakaway control kit

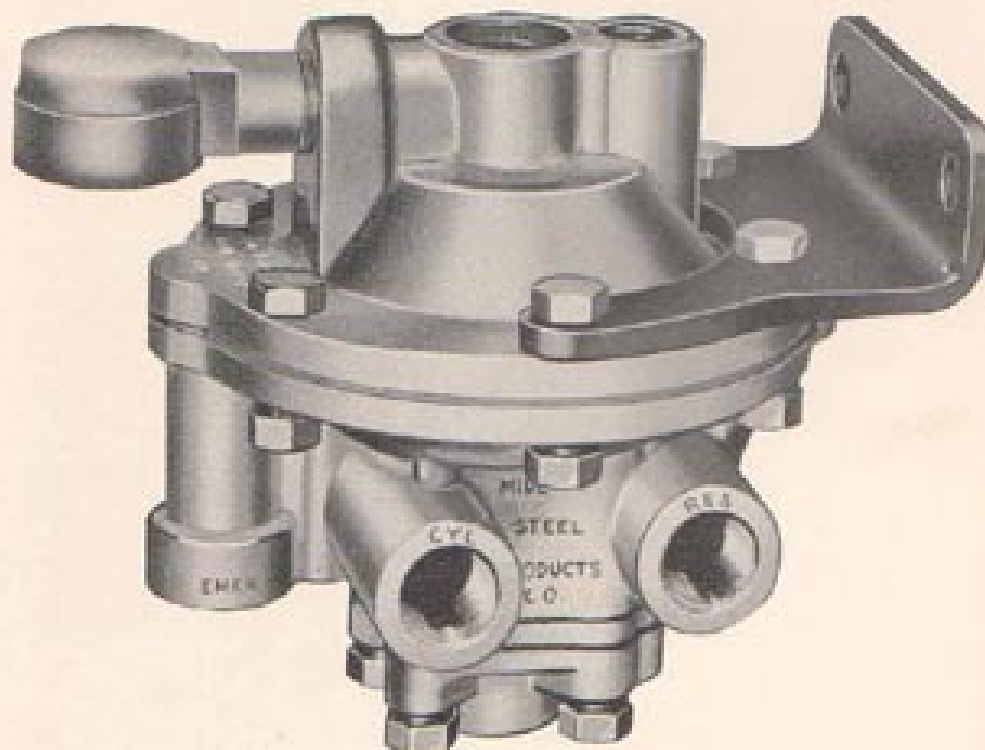

PART NO.	DESCRIPTION	MODEL APPLICATION
2233354	Tractor Breakaway Control Kit	All Air Brake Models

## PRODUCT DATA

All Tractors operating under ICC regulations must be equipped with a device which will conserve the air in the brake system in the event of trailer break away. This unit complies with existing ICC regulation.

It is fully automatic in operation and on the job when needed. Nothing new for driver to learn. Also protects

the Air Brake System if compression discharge line, governor line, first tank or line to emergency coupling is broken.

Easily installed, Kit is complete with Break-a-way Valve, Relay Valve, all necessary fittings and complete installation instructions. Copper tubing and looms not included.

FOR A NEW THRILL DRIVE A GMC TRUCK HYDRAMATIC



# cushion, air cooled

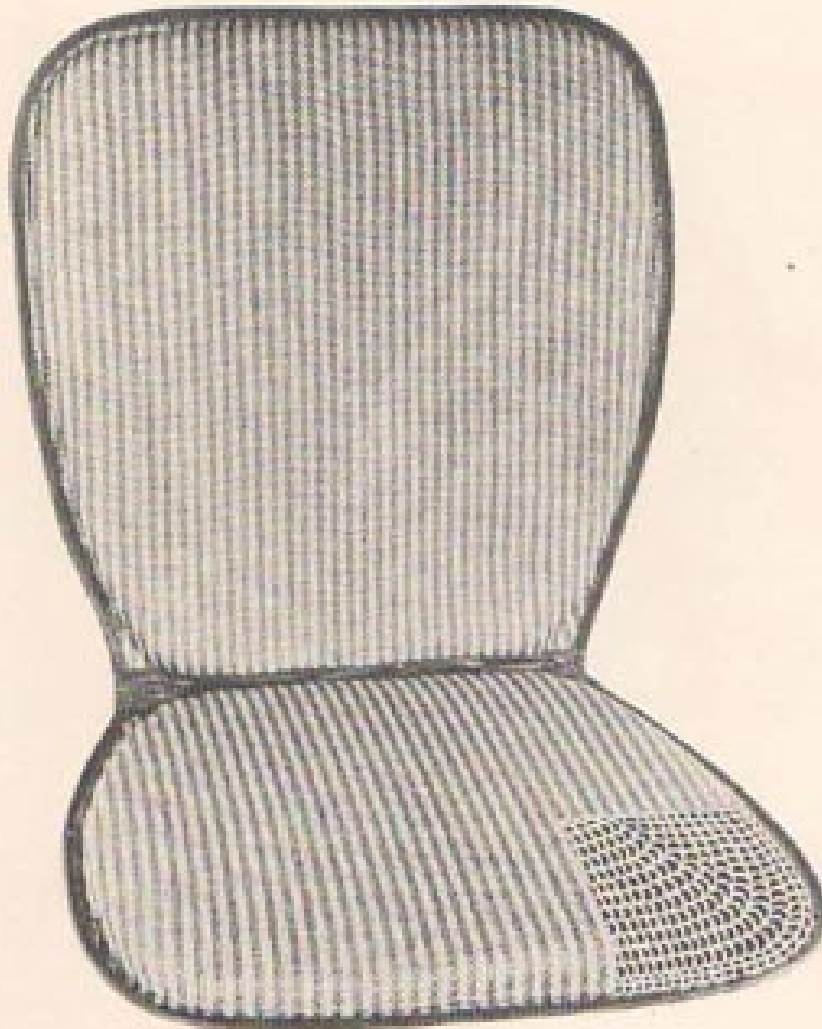

PART NO.	DESCRIPTION	MODEL APPLICATION
2333527	Cushion, air cooled, king size	All

BACK 20" high

COLOR, blue and white

## PRODUCT DATA

GMC "Kool Kooshion" is a real luxury accessory . . . at a low price, to keep drivers cool and comfortable on hot summer days. Perfect ventilation keeps perspiration from trickling down the back of the operator.

Constructed of continuous interlocking coils of spring wire, covered by loosely woven fibre to assure perfect ventilation, it is light in weight and adds immeasurably to driver comfort.



FIT RIGHT—LAST LONGER—WITH THE EXTRA MARGIN OF SAFETY BUILT IN

# extinguishers, fire



PART NO.	DESCRIPTION	MODEL APPLICATION
2233456	Extinguisher, Fire 1 qt.	All
2233457	Extinguisher, Fire 1½ qt.	All
2233458	Fluid—1 qt.	Use with 2233456-2233457 fire extinguishers

## PRODUCT DATA

The fast, sure action of these GMC Fire Extinguishers is sudden death to fire; especially electrical, gasoline and oil fires. Merely turn the handle, left or right, and pump, directing a stream of vaporizing liquid at the base of the flame.

Includes sturdy bracket with metal strap for easy, secure mounting in cab of truck.

Trucks operating under ICC license must carry a 1½ quart fire extinguisher of this type or equal.

FOR A NEW THRILL DRIVE A GMC TRUCK HYDRAMATIC



# filter, gasoline

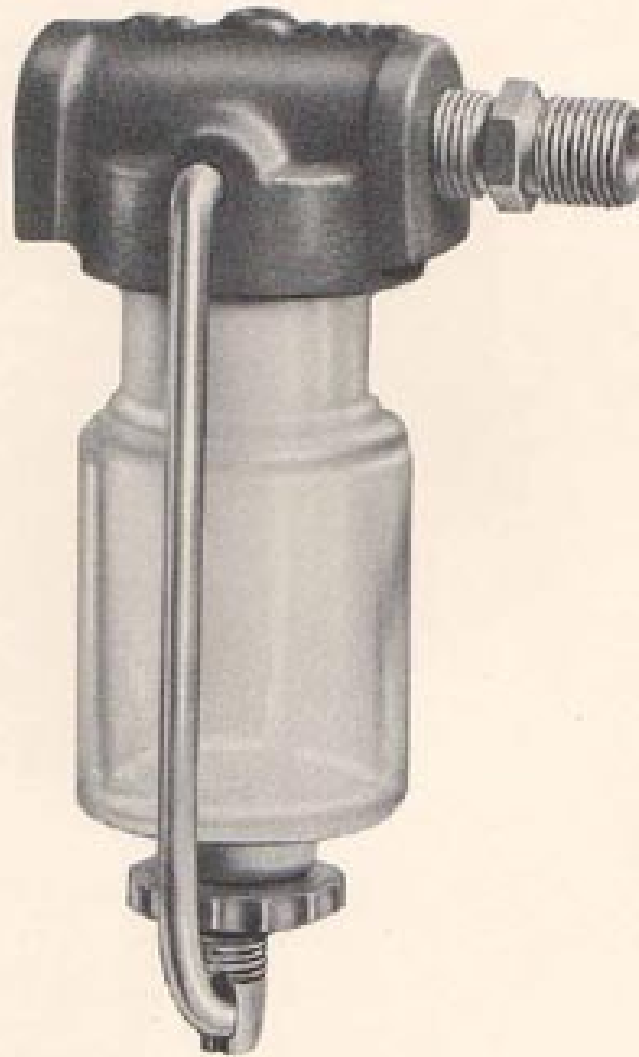

KIT NO.	DESCRIPTION	MODEL APPLICATION
333092	Filter, Gasoline 7/8"	All Gas Engines

## PRODUCT DATA

The Filter is an assembly of non-corrosive brass discs and spacers with openings only three-thousandths of an inch in width—several times finer than openings in 100 mesh wire gauge . . . troublefree and easily serviced.



FIT RIGHT—LAST LONGER—WITH THE EXTRA MARGIN OF SAFETY BUILT IN

# flares, flags, fusees and reflectors

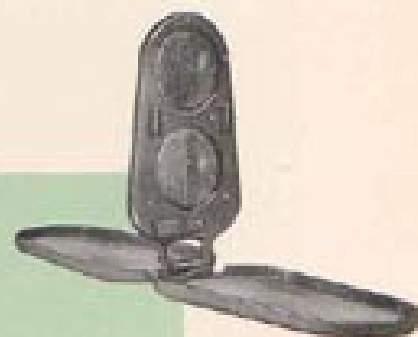
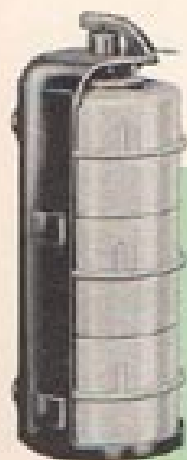

PART NO.	DESCRIPTION	MODEL APPLICATION
2233073	Oil Flare (set of 3 in bkt.)	All
2233074	Oil Flare (set of 3 in case)	All
2233032	Flare, Reflector (set of 3)	All
2233294	Flare, Reflector (set of 3)	All
2233071	Fusee, 30 Minute (case 72)	All
2233442	Fusee, 15 Minute (case 72)	All
2233069	Flag, 15" x 17" Red	All
2233337	Flag Kit	All
2233133	Reflector—Red	All
2233134	Reflector—Amber	All
2233070	Case, Fusee & Flag	All

## PRODUCT DATA

Conveniently packaged and fully approved to meet existing regulations, these accessories completely fill the need for this required type of equipment.

FOR A NEW THRILL DRIVE A GMC TRUCK HYDRAMATIC





# brush type grille guard

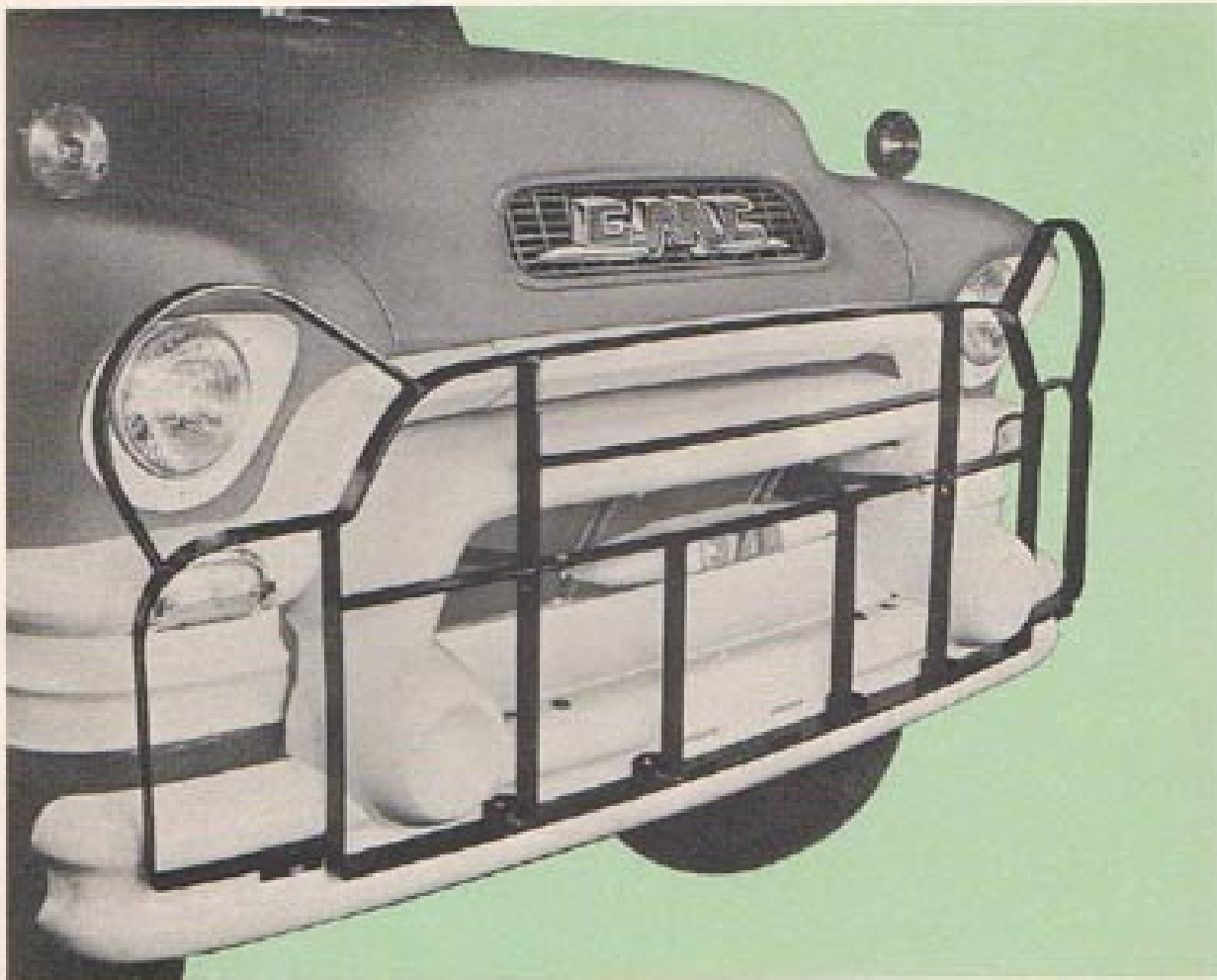

PART NO.	DESCRIPTION	MODEL APPLICATION
2233614	Guard, Grille, Brush Type.	300 thru 370 conv.
2233616	Guard, Grille, Brush Type.	450 thru 670 conv.

## PRODUCT DATA

Specifically designed and engineered for GMC (Models listed above), these sturdy Grille Guards offer strong, rugged front end protection.

GMC Grille Guards brace directly to the frame for maximum rigidity, require no sheet metal cutting or removal, and are complete with all brackets and attaching hardware.



FIT RIGHT—LAST LONGER—WITH THE EXTRA MARGIN OF SAFETY BUILT IN

# GMC heaters and defrosters

## APPLICATION TO TRUCK MODELS

FOR TRUCK MODEL	USE HEATER, PART NUMBER
100 thru 670 Conv. Gas and Diesel F350 thru F600	2233515 Economy 12 Volt 2233517 Air Flow 12 Volt
D930 thru DW970 Conv. F630 thru DF950 COE Gas and Diesel	2233371 H.D. Air Flow 12 Volt

### PRODUCT DATA

Due to the wide variety of bodies which may be mounted on GMC Models PM-150 and PM-250 we cannot offer an engineered heater installation. However, some body build-

ers do make provision for installation of GMC Air Flow type heaters in their truck bodies. Check with your body builder before ordering a heater and defroster.

FOR A NEW THRILL DRIVE A GMC TRUCK HYDRAMATIC



# heavy duty air-flow heater and defroster

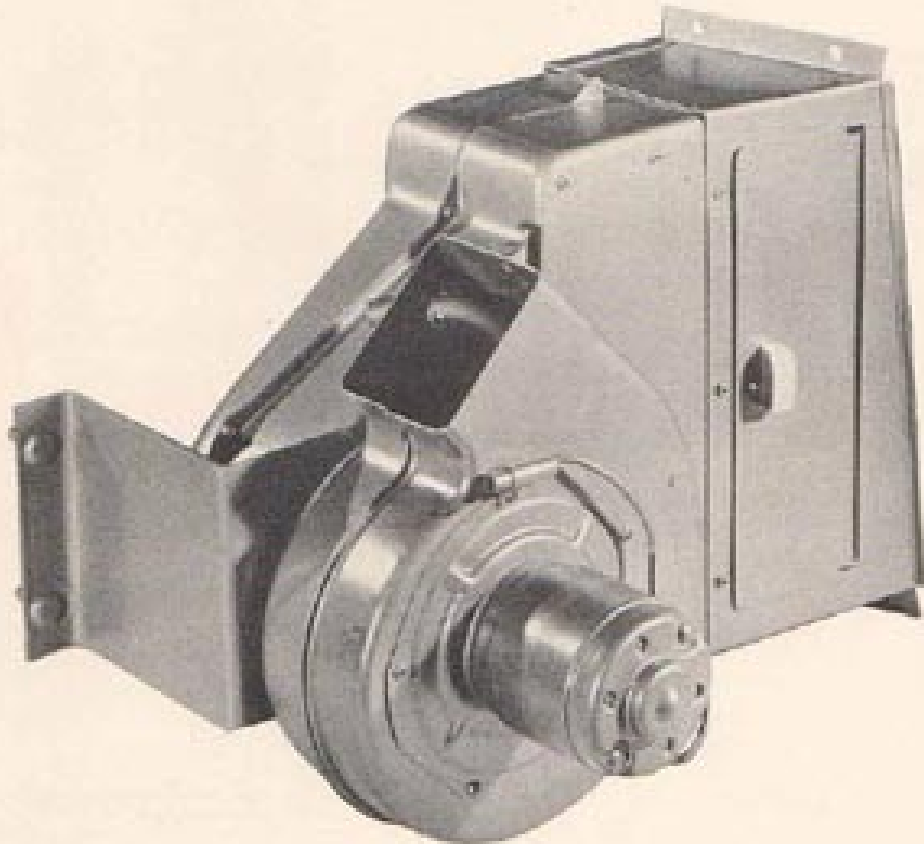

ART NO.	DESCRIPTION	MODEL APPLICATION
233371	Heater and Defroster, Heavy Duty Air Flow 12 Volt	See page 16

## PRODUCT DATA

Tailored for GMC, the heavy duty Air Flow Heater and Defroster, mounts on the right hand side of the cab, over specially designed cab louvers. Cab windows are kept free from fog and moisture by outside air supplied by the heater. Thermostatic water control valve to regulate the flow of heated water through the core is also

featured. The thermostatic valve not only maintains cab temperature constant during cold weather, but will also turn heater off completely permitting unit to be used as a cab ventilator during hot weather. The adjustable ventilating door on the heater permits operator to use heater as an outside air; or recirculating air unit.



FIT RIGHT—LAST LONGER—WITH THE EXTRA MARGIN OF SAFETY BUILT IN

# deluxe air-flow heater and defroster

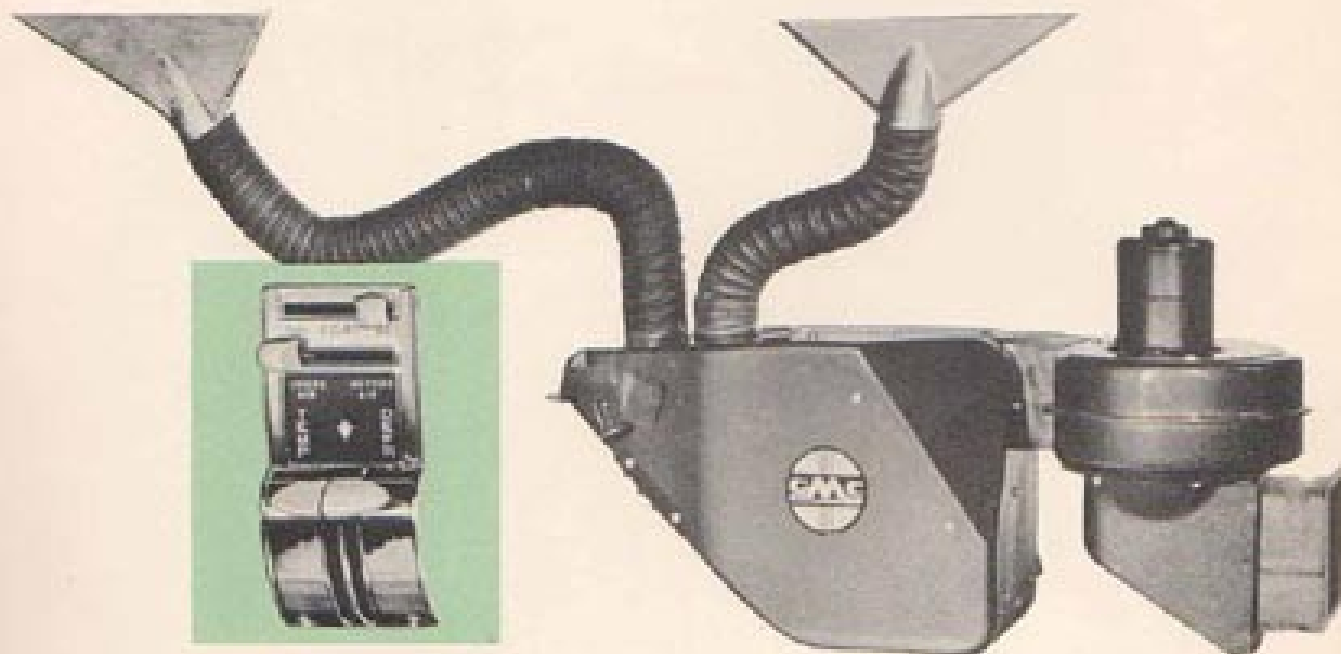

PART NO.	DESCRIPTION	MODEL APPLICATION
2233517	Heater and Defroster, Air Flow Deluxe 12 Volt	See page 16

## PRODUCT DATA

Designed and styled for GMC, the popular Air Flow Heater and Defroster mounts on the right hand side of the cab. The dash mounted, attractively styled chrome control unit harmonizes with the instrument panel and affords finger tip control of the cab temperature and air volume feeding the powerful defrosters.

Large intakes draw outside air from the louvers at the top of the cowl, high above the traffic fumes, into the plenum chamber for redistribution inside the cab. Win-

dows are kept free from fog and moisture by the ample volume of air supplied to the heavy duty defrosters.

Thermostatic water control valve, regulating the flow of heated water to the core, assures maintaining a constant cab temperature during cold weather; and also provides for turning the heater off completely, to use the unit to ventilate the cab during hot weather.

Adjustable controls permit the operator to utilize this unit either as an outside air; or recirculating unit.

FOR A NEW THRILL DRIVE A GMC TRUCK HYDRAMATIC



# economy heater and defroster



UNIT NO.	DESCRIPTION	MODEL APPLICATION
233515	Heater and Defroster Economy 12 Volt	See Page 16

## PRODUCT DATA

**ECONOMY HEATER**—The GMC Economy Heater and Defroster is a combination unit designed to provide low cost heating and defrosting for operators preferring this

type of heating equipment. It features large defroster hoses, defroster air control and selective motor speed switch.



FIT RIGHT—LAST LONGER—WITH THE EXTRA MARGIN OF SAFETY BUILT IN

# towing hooks and pins

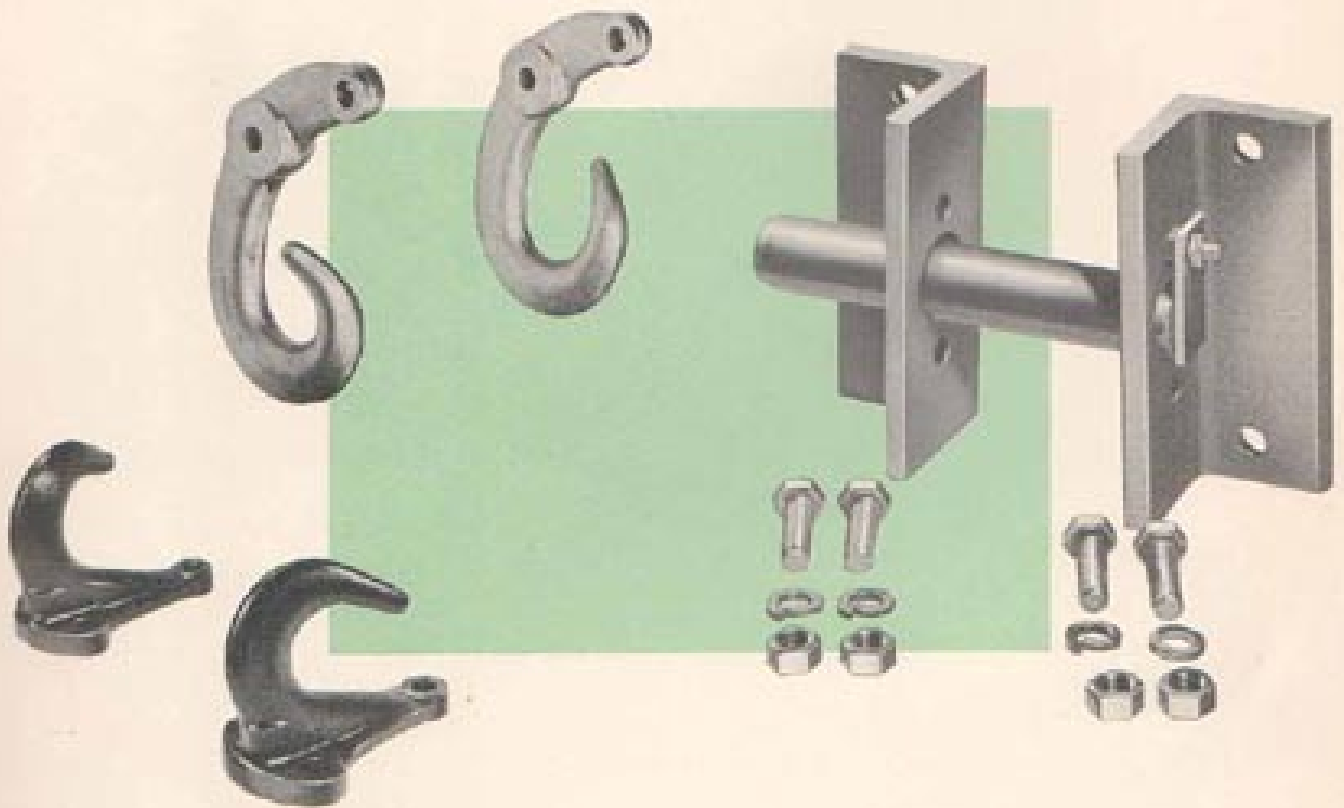

For rear installation additional parts must be used as shown on the instruction sheet included in the carton of 2233508.

Tow Hook Packages are released for Standard Models only. For Models where rear frame cut-off is necessary, as on tractors, dumps, etc. Package 2233508 can be used for parts only; location of hooks to be determined by available frame space for attachment.

PART NO.	DESCRIPTION	MODEL APPLICATION
2233563	Pin, Tow (Fr.) Front	450 thru 670 Conv. F550 thru F660 COE
2233504	Hooks, Tow (Fr.) Front	100 thru 370 Conv. F350 thru F450 COE
2233506	Installation Kit, Front	Required to install 2233504 Front Tow Hooks on 100 thru 250
2233508	Hooks, Tow (Fr.) Rear	300 thru 970

## PRODUCT DATA

**Tow Hooks**—These packages include 2 forged steel Tow Hooks, attaching nuts, bolts, lock washers and a complete installation instruction sheet.

**Tow Pins**—This package includes 2 steel Tow Pins and all necessary mounting parts plus complete installation

instruction sheet.

**NOTE:** When mounting front tow hooks 2233504 on Models 100 thru 250, Installation Kit 2233506 must also be used.

FOR A NEW THRILL DRIVE A GMC TRUCK HYDRAMATIC



# chrome dual air horns



ITEM NO.	DESCRIPTION	MODEL APPLICATION
3573	Horn, Dual Air, Chrome	All Air Brake Models

## PRODUCT DATA

Horns are designed for very low air consumption and do not affect the air brake system. The control valve is made of a brass casting, precision machined for positive action and long service. Can be operated to provide a wide

sound range from a mild toot to a powerful blast for distance.

Length of Horn set is 16".



FIT RIGHT—LAST LONGER—WITH THE EXTRA MARGIN OF SAFETY BUILT IN

# hose tenna

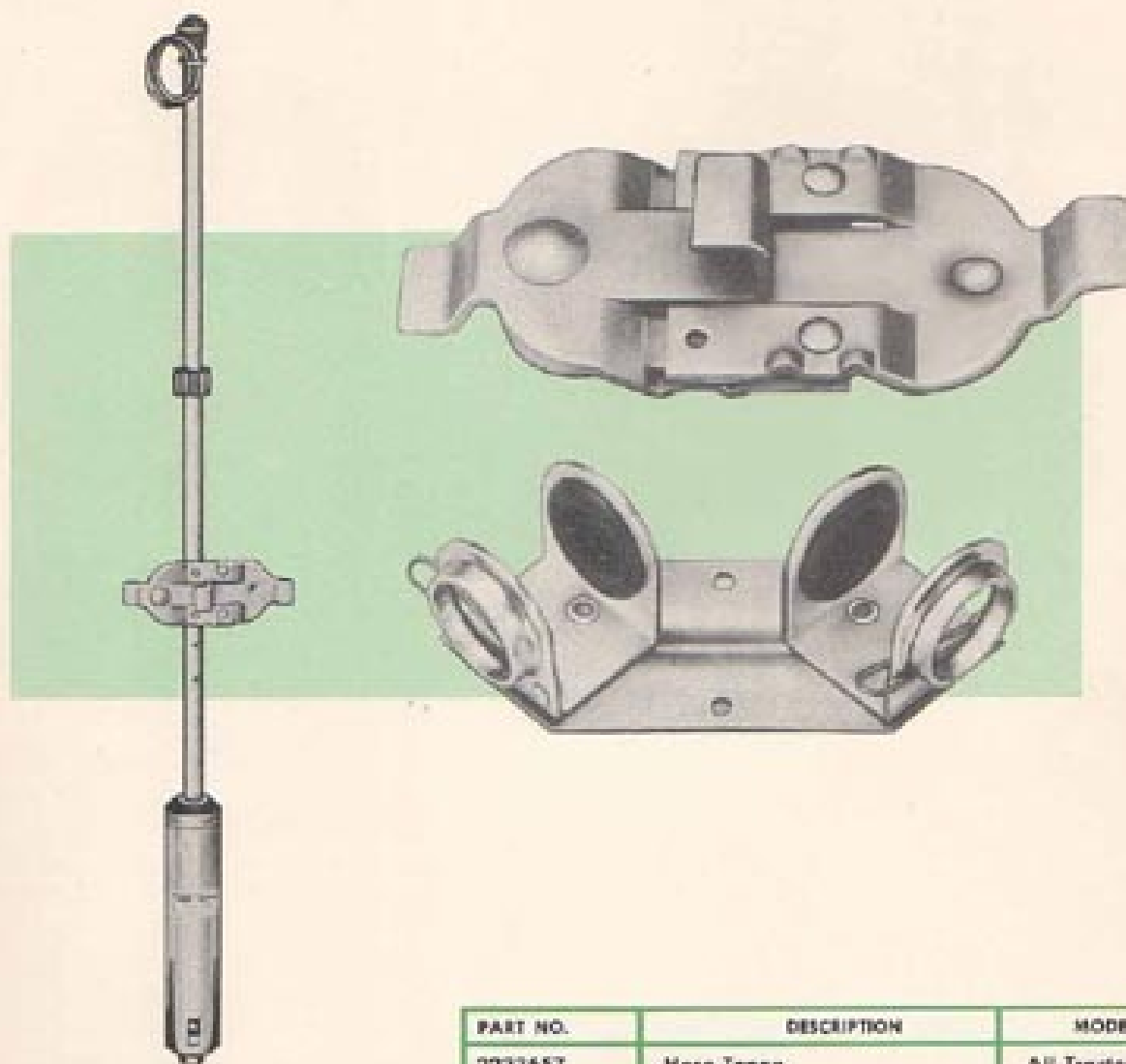

PART NO.	DESCRIPTION	MODEL APPLICATION
2233657	Hose Tenna	All Tractors
2233658	Air Hose Holder	All Tractors
2233659	Vacuum Hose Holder	All Tractors

## PRODUCT DATA

A highly practical, fully adjustable unit for use on any tractor-trailer. Protects and tends electric cables, air and vacuum hoses. Bends in all directions except toward cab and prevents hose cramping and dragging. Saves wear

and tear on hoses . . . makes coupling easier.

All parts are rust proofed and treated to ensure long, dependable service.

FOR A NEW THRILL DRIVE A GMC TRUCK HYDRAMATIC





# hydraulic jacks



## PRODUCT DATA

The GMC line of Hydraulic Jacks features a wide range so operators may select the type of equipment required. Manufactured to perform difficult lifting jobs, they are sturdy, dependable and feature the following:

1. **SELF-LOCK SCREW INTEGRAL CAP**—Forged from high carbon steel in single unit to prevent loosening or loss of caps. Radial cap flutes provide skidproof grip.
2. **LEAK-PROOF POWER CYLINDER**—Seamless-steel power cylinder is sealed into jack base so it won't leak even under tremendous pressure.
3. **RYTH-MATIC VALVE ACTION**—Suction and discharge valves operate with swift, positive closing action that assures smooth easy lifting power.
4. **PENDULUM-BALANCED FOR EASY POSITIONING**—When lifted by handle, jack automatically takes upright position making it easy to locate jack under load.
5. **TOUGH, LONG-LASTING LEATHERS**—High quality, specially impregnated leathers do not become soft and flabby from the jack fluid.
6. **MICRO-ACCURATE SAFETY RELEASE**—Provides complete control of lowering speed. Operated from safe distance with aid of bayonet in end of jack handle.
7. **NON-WOBBLING, NON-TIPPING BASE**—Tough malleable iron casting, ribbed for extra strength. Large area base is scientifically designed to avoid tipping and wobbling.

PART NUMBER	SIZE
2233037	3 Ton
2233038	5 Ton
2233039	8 Ton
2233040	12 Ton



FIT RIGHT—LAST LONGER—WITH THE EXTRA MARGIN OF SAFETY BUILT IN

# GMC courtesy lamps—pair



PART NO.	DESCRIPTION	MODEL APPLICATION
2233634	GMC Courtesy Lamps—pair	100-670; F350-F600

## PRODUCT DATA

GMC courtesy lamps mount on the lower edge, at the outer ends of the instrument panel. Wired with an automatic switch, they afford full illumination of the cab floor and step well when either or both doors are opened.

Each kit is complete with 2 courtesy lamps, 2 door switches, wiring, all attaching parts and full instructions for quick, easy installation.

FOR A NEW THRILL DRIVE A GMC TRUCK HYDRAMATIC



# cigarette lighter

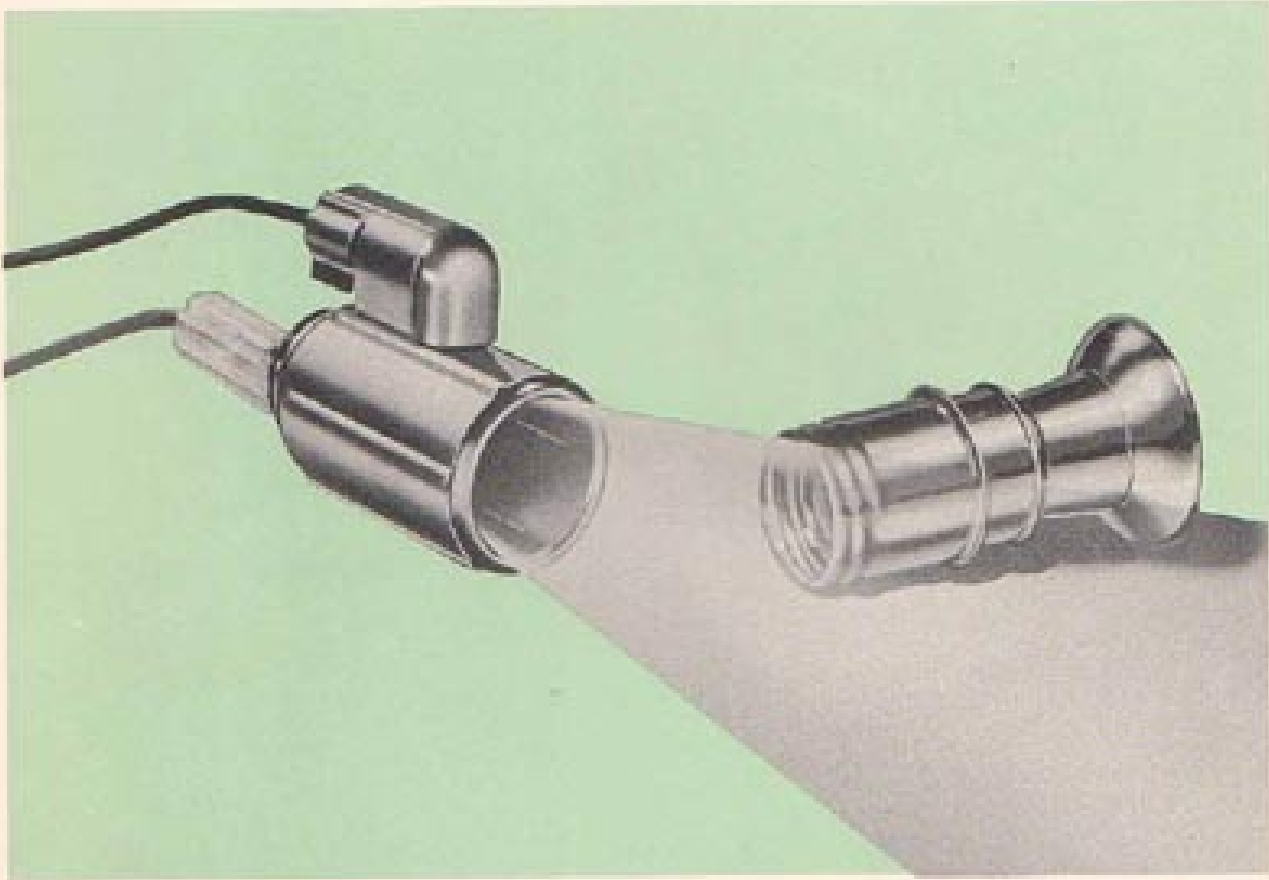

12 Volt—Part No. 2233470

## PRODUCT DATA

GMC Lighters, of the pop-out type, feature an ash shield to reduce the danger of spark or hot ash falling upon clothing or upholstery with resultant damage. With fully illuminated socket, the lighter is easily replaced even at

night.

A very useful and desirable safety convenience which makes it unnecessary to remove both hands from the wheel—as with matches . . . makes driving safer.



FIT RIGHT—LAST LONGER—WITH THE EXTRA MARGIN OF SAFETY BUILT IN

# streamlined marker lights

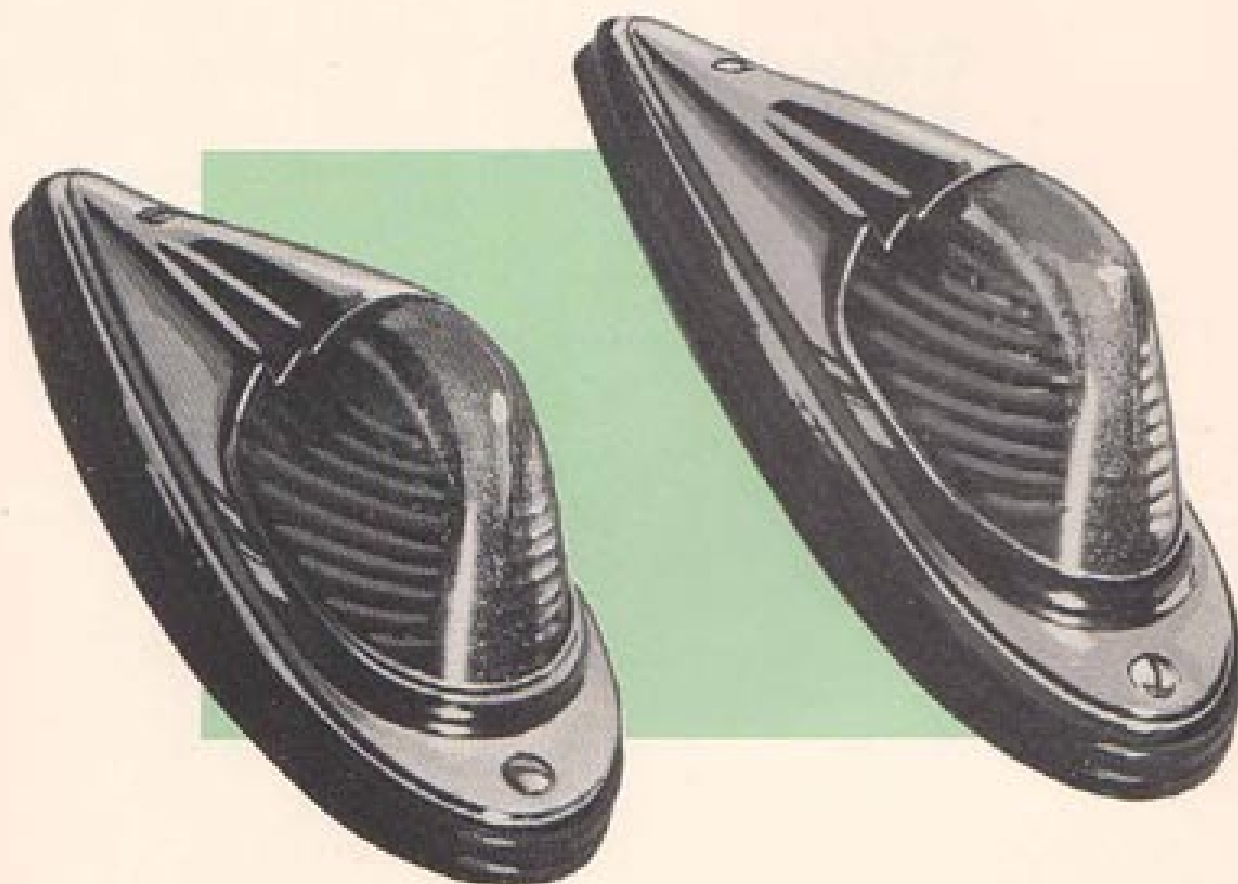

PART NO.	DESCRIPTION	MODEL APPLICATION
2233519	Light, Marker, Aluminum Finish 6 Volt	All 6 volt
2233521	Light, Marker, Aluminum Finish 12 Volt	All 12 volt
2233523	Light, Marker, Chrome Finish 6 Volt	All 6 volt
2233525	Light, Marker, Chrome Finish 12 Volt	All 12 volt

## PRODUCT DATA

GMC Streamlined Clearance Marker Lights are individually packaged in either chrome or aluminum paint finish. Package includes lamp, bulb, all mounting parts, large rubber gasket, locating template and installation instruc-

tion sheet.

Factory installed wiring on all models 300 thru 670 Conv. and F350 thru F600 COE eliminate necessity for wiring harness.

FOR A NEW THRILL DRIVE A GMC TRUCK HYDRAMATIC



# clearance and marker lights

**ARMORED CLEARANCE/MARKER  
W/3 CANDLEPOWER BULB**



6 Volt—2233529 Amber—2233531 Red  
12 Volt—2233482 Amber—2233484 Red

**FLUSH MTG. CLEARANCE/MARKER  
W/2 CANDLEPOWER BULB**



6 Volt—2233145 Amber—2233147 Red  
12 Volt—2233490 Amber—2233492 Red

**BEEHIVE CLEARANCE/MARKER**



6 Volt—2233143 Amber—2233144 Red  
12 Volt—2233456 Amber—2233458 Red

**HINGED BRACKET CLEARANCE/MARKER**



6 Volt—2233145 Red  
12 Volt—2233494 Red

## PRODUCT DATA

This full line of Clearance and Marker Lights enables operators to select the type of equipment desired to meet local or interstate regulations.



FIT RIGHT—LAST LONGER—WITH THE EXTRA MARGIN OF SAFETY BUILT IN

# spot lamp with mirror



PART NO.	DESCRIPTION	MODEL APPLICATION
2233585	Spot Lamp With Mirror	100 thru 670; F350-P600

## PRODUCT DATA

A deluxe spot lamp of streamlined, modern design with recessed rear view mirror behind the lamp head . . . easily adjusted from inside cab. Heavily chrome plated for beauty and durability.

The powerful, precision focused sealed beam lamp pro-

jects a bright beam of light up to 1000 feet.

Features pillar post mounting for easy installation. Mounting bracket may be reversed, for right hand as well as left hand installation.

FOR A NEW THRILL DRIVE A GMC TRUCK HYDRAMATIC



# right hand stop and tail lights



KIT NO.	DESCRIPTION	MODEL APPLICATION
233639	Light, R.H. Stop & Tail	All

## PRODUCT DATA

Designed and engineered for GMC trucks, this R.H. Stop and Tail Light matches the left hand light in appearance, shape and finish.

Features new, improved lens design for increased safety and signaling power.



FIT RIGHT—LAST LONGER—WITH THE EXTRA MARGIN OF SAFETY BUILT IN

# seven inch stop light



PART NO.	DESCRIPTION	MODEL APPLICATION
2233496	Stop Light 7"	All 12 volt

## PRODUCT DATA

Safety minded operators will find this large 7" Stop Light ideal.

Painted black enamel with a stainless steel door, it has

a detachable L-shaped bracket with four mounting bolts on 2" centers; bracket permits vertical or horizontal mounting. The 7" red glass lens has refracted letters "STOP" molded in.

FOR A NEW THRILL DRIVE A GMC TRUCK HYDRAMATIC





# inside non-glare mirror and bracket

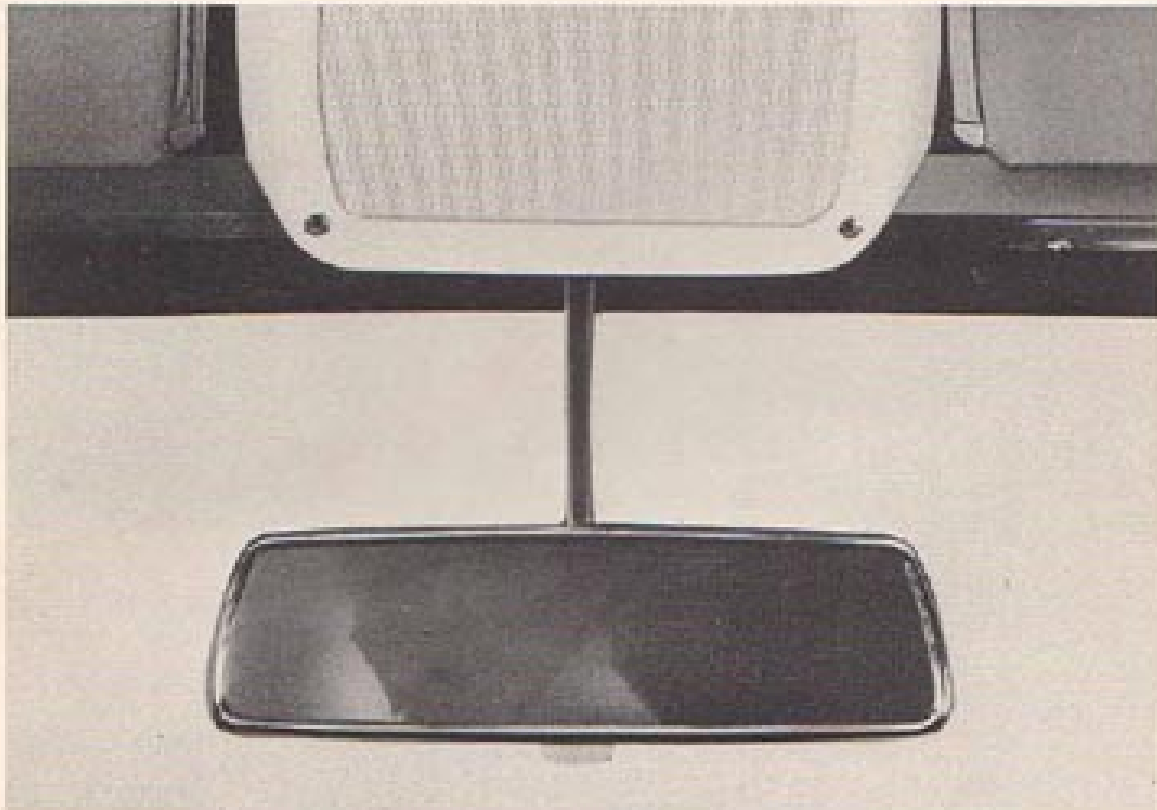

PART NO.	DESCRIPTION	MODEL APPLICATION	
2233509	Mirror, Inside Glare Proof	100-670	F350-F600
2233655	Bracket (1 required for each installation)	Same	

## PRODUCT DATA

This outstandingly useful Mirror enables drivers to see lights approaching from the rear without objectionable glare. It is constructed on a prism principle enabling the

operator to regulate the Mirror for day or night driving. Once used, operators will find it an indispensable piece of equipment.



FIT RIGHT—LAST LONGER—WITH THE EXTRA MARGIN OF SAFETY BUILT IN

# fender mirror



PART NO.	DESCRIPTION	MODEL APPLICATION
2233376	Mirror, Fender	All

## PRODUCT DATA

GMC Fender Mirrors are a sound investment in safety and driver convenience that facilitate maneuvering in traffic and congested areas.

The mirror head has a uniform curvature diminishing lens, 5½" outside diameter, mounted in rubber.

Mounted to the fender by a single ½" bolt, flanged

mounting cup and heavy gasket, the mirror is fully adjustable at base and head. The extension is 12" closed—17" fully extended.

NOTE: Mirror Arm Brace 2233267 may also be used with this fender mirror.

FOR A NEW THRILL DRIVE A GMC TRUCK HYDRAMATIC



# GMC rear view mirrors

## APPLICATION TO TRUCK MODELS

<i>Mirror No. and Type</i>	<i>For Models</i>
2233551 R.H. Short Fixed Arm 5" Round Head	100 thru 250
2233553 R.H. Extension Arm 5" Round Head	100 thru 670 Conv. F350 thru F600 COE
2233555 R.H. Extension Arm 5" x 9" Rectangular Head	100 thru 670 Conv. F350 thru F600 COE
2233549 R.H. Mirror Reinforcement	Must be used to reinforce R.H. door when installing R.H. Mirror 2233551-553-555
2233330 R.H. Extension Arm 5" x 9" Rectangular Head	900 and up Conv. F630 and up COE
2233455 Bus Type, Pair R.H. & L.H. 6" x 16" Head	900 and up Conv. F630 and up COE
2233557 Bus Type, Pair R.H. & L.H. 6" x 16" Head	300 thru 670 Conv. F350 thru F600 COE
2233644 Bus Type (one) R.H. or L.H. 6" x 12" Head	All
2233267 Brace, Mirror Arm	All Tubular Arm Mirrors

### PRODUCT DATA

Right hand outside rear view Mirrors add immeasurably to driving safety. They match left hand Mirrors furnished in production and offer the operator an increased field of rear vision. Mirror heads furnished on

these assemblies are of an improved type to eliminate weathering, clouding and peeling. All packages are complete with mounting brackets, templates and attaching nuts and bolts.



FIT RIGHT—LAST LONGER—WITH THE EXTRA MARGIN OF SAFETY BUILT IN

# outside rear view mirrors



Mirror reinforcement 2233549 shown at right must be used to reinforce R.H. door when installing any one of the three R.H. mirrors illustrated above on conventional models only.

FOR A NEW THRILL DRIVE A GMC TRUCK HYDRAMATIC



# outside bus type mirrors

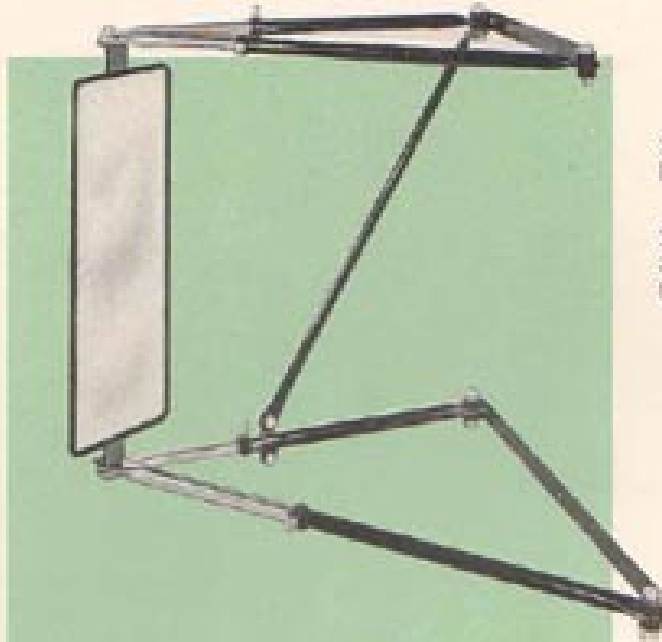

2233455 SIZE 6 x 16  
ILLUSTRATED

2233557 SIZE 6 x 16  
SIMILAR  
(not shown)

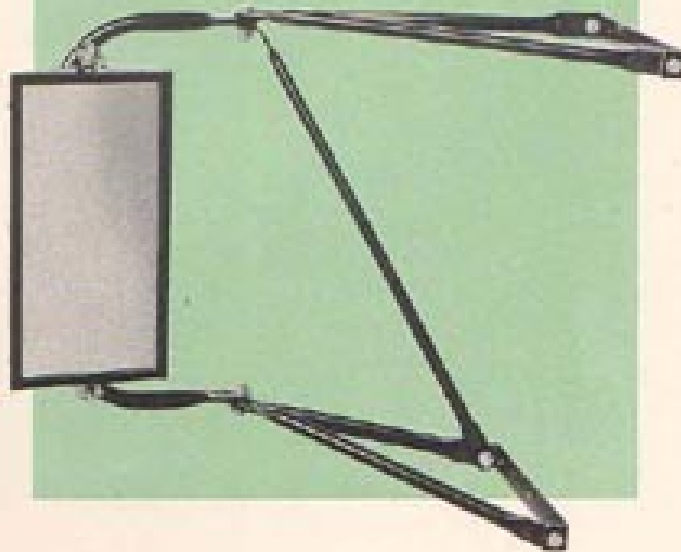

2233644 SIZE 6 x 12  
ILLUSTRATED



FIT RIGHT - LAST LONGER - WITH THE EXTRA MARGIN OF SAFETY BUILT IN

# hood ornament

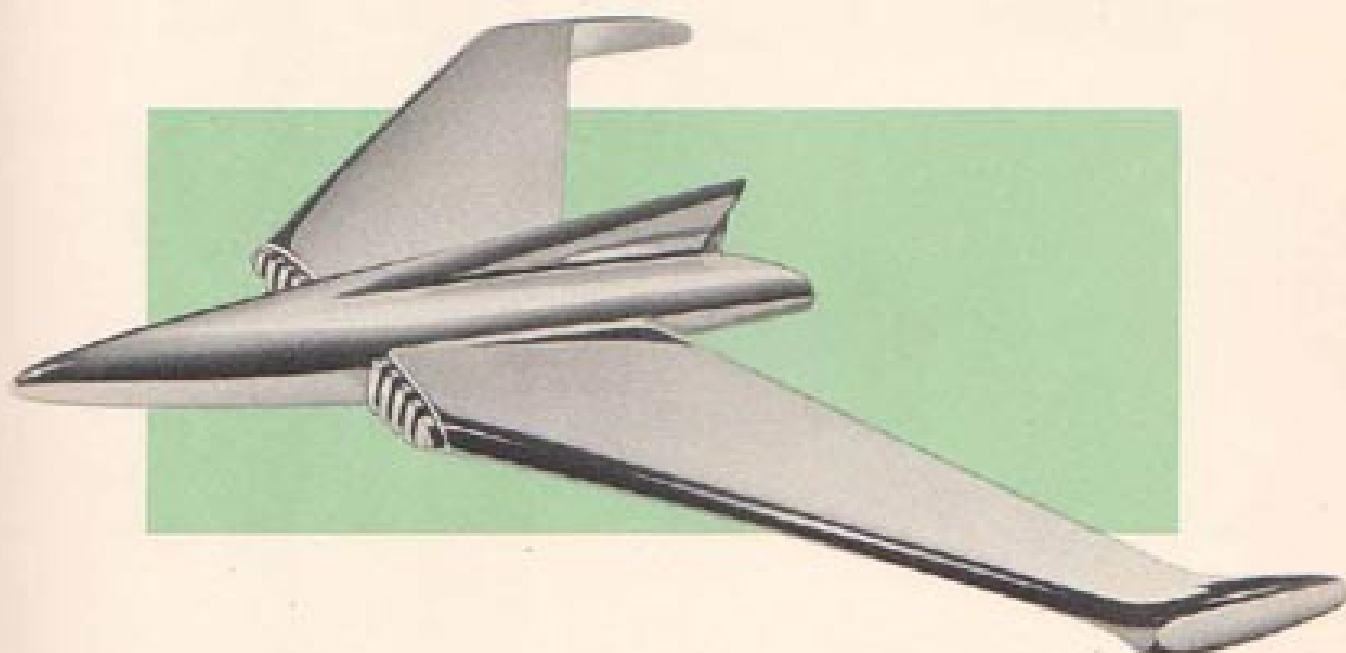

PART NO.	DESCRIPTION	MODEL APPLICATION
3233548	Hood Ornament, Chrome	100-370 Conv. F350-F600 COE

## PRODUCT DATA

Exclusively tooled for GMC, The New Hood Ornament features distinctive, futuristic styling of outstanding beauty and adds that ultra streamlined appearance desired by many owners and operators.

Contoured to fit, it features easy installation, quality construction and hard, durable chrome finish for lasting beauty.

FOR A NEW THRILL DRIVE A GMC TRUCK HYDRAMATIC



# radio and antenna

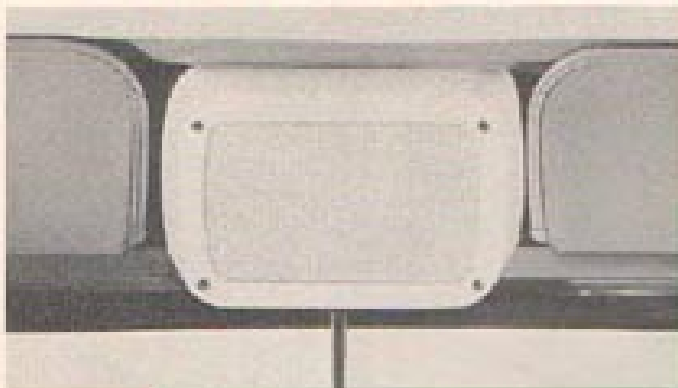

PT. NO.	DESCRIPTION	MODEL APPLICATION
33480	Radio w/ Speaker 12 volt	All
33579	Antenna	All

For ease of installation, the cab header panel of all models 100-670 Conv. and T350-1600 incorporate a special factory die cut knock out plate with mounting holes pre-center punched.

Speaker lead wire is factory installed in all trucks of the above model range eliminating the tedious task of running the lead wire from radio, through cab corner post to speaker.

## PRODUCT DATA

GMC Truck Radio, with five tubes plus rectifier and powerful super-heterodyne circuit, features an automatic volume control to eliminate station fading and a rheostat-type control to vary the delicate tonal shadings from treble to bass.

Alnico permanent magnet speaker is independently

mounted in the cab header panel for improved performance and listening pleasure. Styled to match the GMC instrument panel, the radio is dash mounted for easy accessibility.

The chrome plated brass, telescoping antenna is readily installed on the R.H. fender.



FIT RIGHT—LAST LONGER—WITH THE EXTRA MARGIN OF SAFETY BUILT IN

# resin repair kit



Unexcelled for quick permanent repairs to sheet metal, and especially suited to renovation of used trucks. This easy to use repair kit enables the average mechanic to turn out a job of professional quality, simply by following the clearly outlined instructions included with the kit.

PART NO.	DESCRIPTION	MODEL APPLICATION
2233617	Resin Repair Kit	All models
2233618	Hardener—1 lb. can	All models
2233619	Resin—2 lb. can	All models
2233620	Roving— $\frac{1}{2}$ lb. can	All models
2233621	Fiberglass Cloth— $3\frac{1}{2}$ sq. yd.	All models
2233622	Filler— $\frac{1}{2}$ lb. can	All models

## PRODUCT DATA

Requires little or no preparation for use . . . and is impervious to temperature changes. Does not rust, corrode, chip or craze. The fiberglass base is actually stronger than body sheet metal; and the shrinkage coefficient is less than 2%.

All the necessary components (as listed) along with complete instructions for various applications are con-

tained in the kit.

For further details on this amazing new development refer to Booklet X5538, entitled, "The Low Cost Resin to Sheet Metal Repair System" . . . mailed to all GMC Dealers with Dealer General Service Letter (unnumbered) September 27, 1955.

FOR A NEW THRILL DRIVE A GMC TRUCK HYDRAMATIC





# arm rest

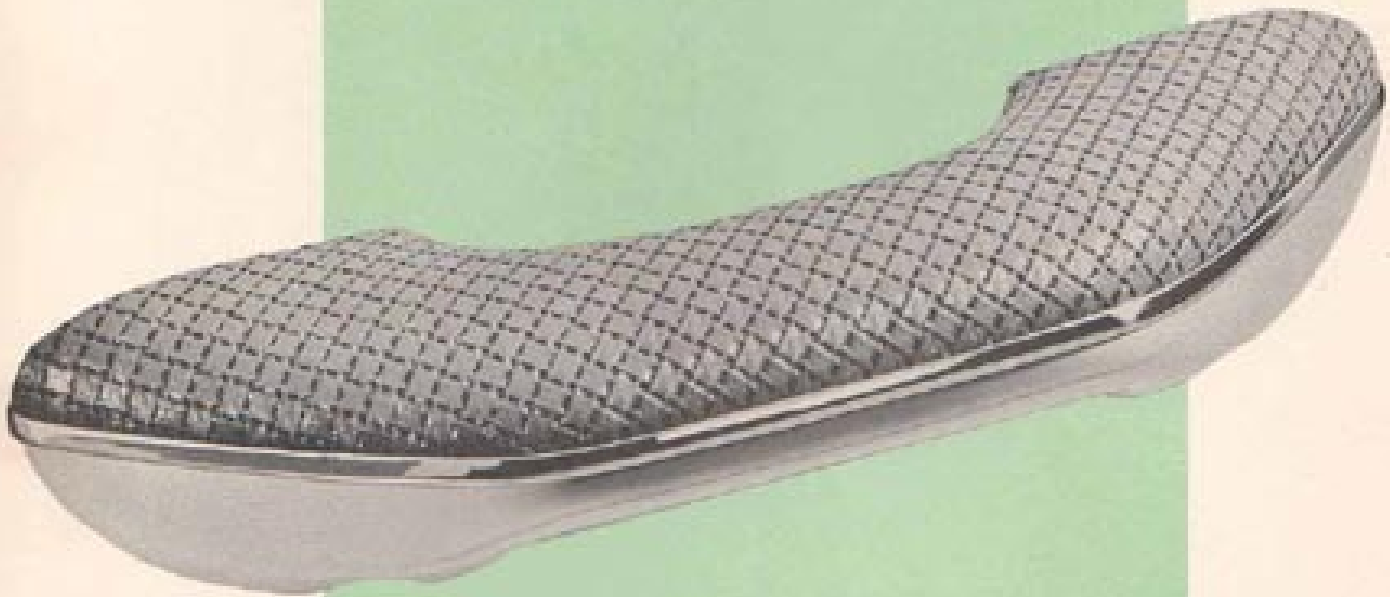

RT NO.	DESCRIPTION	MODEL APPLICATION
33460	Arm Rest Blue	100 thru 670 Conv. F350 thru F600 COE
33462	Arm Rest Green	100 thru 670 Conv. F350 thru F600 COE
33464	Arm Rest Brown	100 thru 670 Conv. F350 thru F600 COE
33466	Arm Rest Gray	100 thru 670 Conv. F350 thru F600 COE

## PRODUCT DATA

GMC Arm Rests in colors and style to match the new two tone interiors of the GMC cabs are available for R.H. or L.H. installation.

Sturdily built, and of new improved design, they add immeasurably to driving comfort and cab styling.



FIT RIGHT—LAST LONGER—WITH THE EXTRA MARGIN OF SAFETY BUILT IN

# seat, level ride 80 and companion



PART NO.	DESCRIPTION	MODEL APPLICATION
2233590	Seat, Level Ride 80	900 & up, F630 and up
2233591	Seat, Level Ride 80	100 thru 670
2233592	Seat, Companion	100 thru 670

## PRODUCT DATA

The GMC-Bostron Level Ride Model 80 offers drivers the ultimate in riding and seating comfort. Greatly increases safety by reducing driver fatigue. It is especially desirable for long over-the-road hauls, or off-the-road operations.

New rubber torsion spring suspension is designed to absorb road shock, and five adjustments accommodate driver weights ranging from 100 to 275 pounds. Seat top and back are fully foam rubber padded.

FOR A NEW THRILL DRIVE A GMC TRUCK HYDRAMATIC



# illuminated arm signal

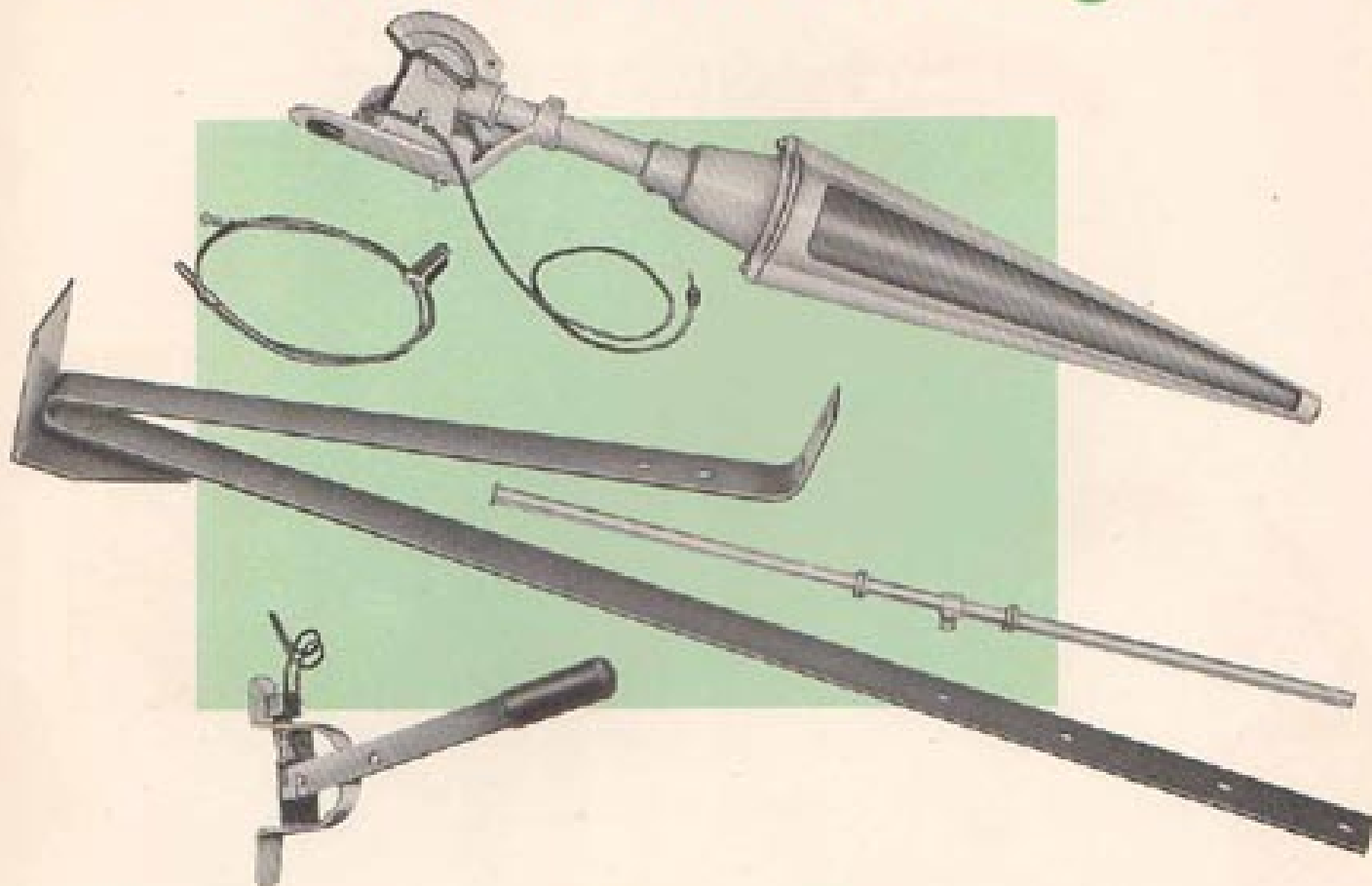

PART NO.	DESCRIPTION	MODEL APPLICATION
233641	Signal, Illuminated Arm	All 300 and up

## PRODUCT DATA

Complies with S.A.E. and State Laws (where required).

Full 12" length of illuminated lens.

Effective day or night.

Complete with Signal, Control, Automatic Switch and all parts for complete installation.

Mounting bracket covers maximum 8 feet body width. Can be shortened for narrower body installation.



FIT RIGHT—LAST LONGER—WITH THE EXTRA MARGIN OF SAFETY BUILT IN

# directional signals

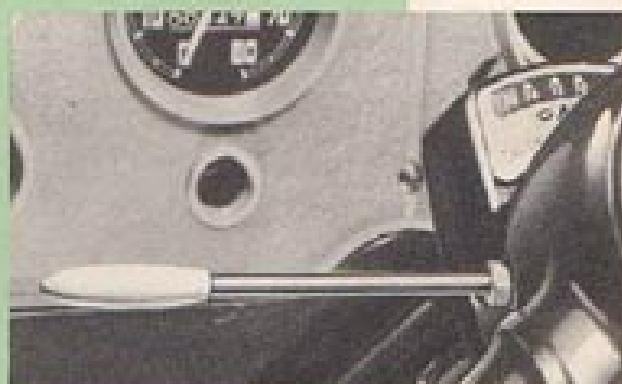
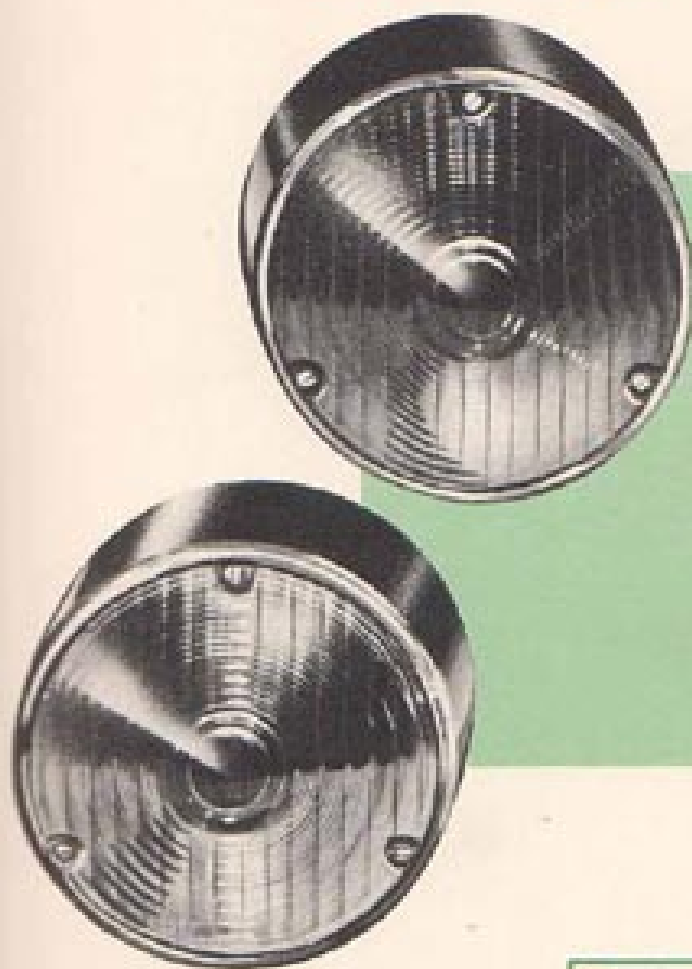

For rear mounting, the following lamps may be installed in conjunction with the Class "A" Kits:

GROUP NO.	PART NO.	DESCRIPTION
22.1015	897331	Lamp, Rear Single Face, Bkt. Mtg. 12 volt

PART NO.	DESCRIPTION	MODEL APPLICATION
2233650	Directional Signals Class "B" w/self cancelling switch	All pickups
2233652	Directional Signals Class "A" Frt. Double Face and Switch	All class "A"

## PRODUCT DATA

These Class "A" Directional Signal Kits contain 2 front double face light weight lamps, self cancelling switch, flasher and all necessary mounting parts. The self cancelling switch has been designed for the truck and when installed in the steering wheel hub gives a finished, neat appearance.

The Class "B" Directional Signal Kits for all pickups utilize the parking lamps and stop and tail lamps. The kit includes new parking lamp sockets and bulbs. A R.H. rear stop and tail lamp, the streamlined self cancelling switch, flasher and all mounting parts.

FOR A NEW THRILL DRIVE A GMC TRUCK HYDRAMATIC



# auxiliary spring

SINGLE LEAF TYPE ILLUSTRATED

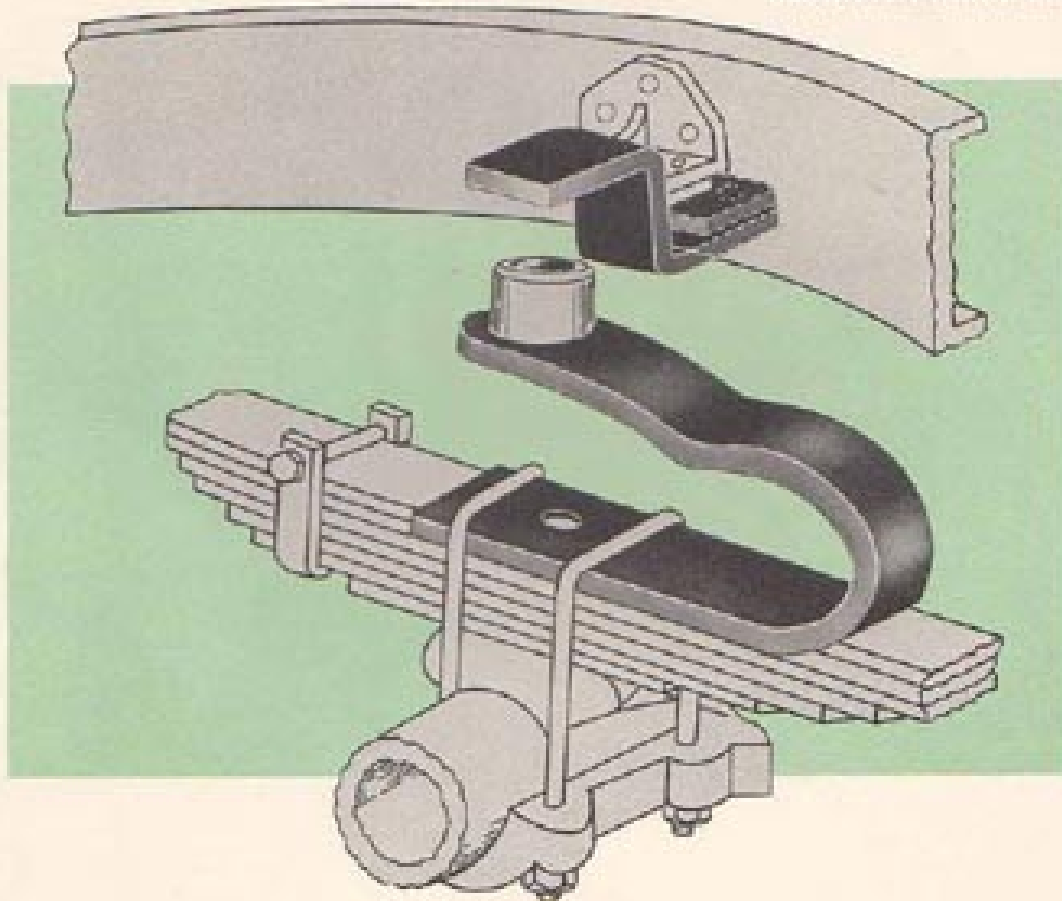

ART NO.	DESCRIPTION	MODEL APPLICATION
133450	Springs, Auxiliary Single Leaf	All 100 & 150 except PM150
133581	Springs, Auxiliary Multiple Leaf	All 100
133589	Springs, Auxiliary Multiple Leaf	All 150 except PM150

## PRODUCT DATA

GMC Auxiliary Springs afford improved load stability and protection from overload.

Kit is complete with springs, brackets, attaching parts and contains full instructions for quick, easy installation.

Use of GMC Auxiliary Springs does not change the currently published manufacturers' recommended gross ratings for vehicle warranty.



FIT RIGHT—LAST LONGER—WITH THE EXTRA MARGIN OF SAFETY BUILT IN

# electric tachometer



PART NO.	DESCRIPTION	MODEL APPLICATION
2233600	Tachometer, Electric	All 8 Cyl. Gas Engines— 12 v
2233648	Tachometer, Electric	All 6 Cyl. Gas Engines— 12 v

## PRODUCT DATA

A long life, precision made Electric Tachometer with illuminated dial; designed to mount in the instrument panel, and styled to match the other instruments of the truck. Featuring ease of installation, it will maintain its accuracy at any temperature or voltage variation. The kit

is complete with Tachometer Head, Sending Switch (Distributor Mounting Type), Cable Assembly, all attaching parts and includes a sheet of detailed instructions for installation.

FOR A NEW THRILL DRIVE A GMC TRUCK HYDRAMATIC



# right hand inside sun visor

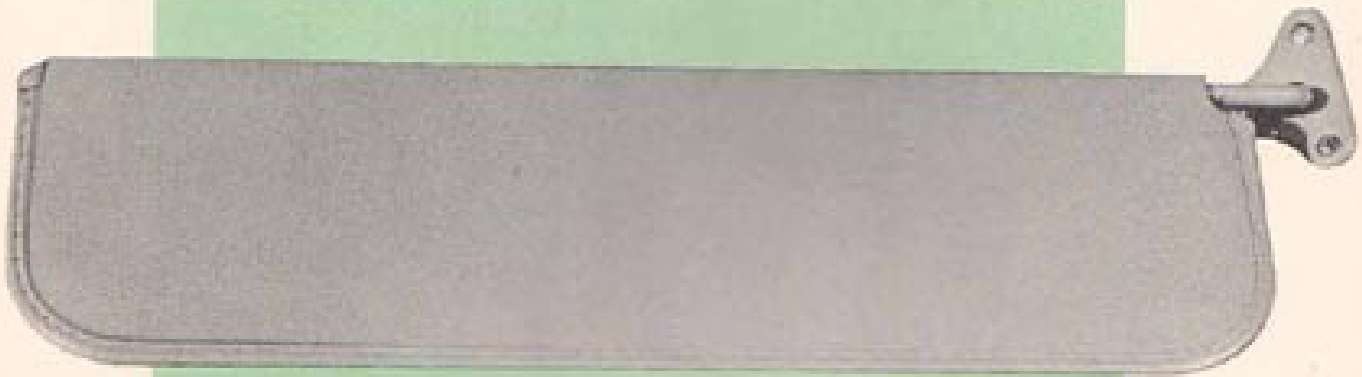

PART NO.	DESCRIPTION	MODEL APPLICATION
333474	Visor, Sun, R. H. Inside	All small cab

## PRODUCT DATA

This Right Hand Inside Sun Visor is available for operators who desire complete cab sun protection. It matches the left hand sun visor furnished by production,

and adds immeasurably to cab and driving comfort. Full installation instructions and parts included in the package.



FIT RIGHT—LAST LONGER—WITH THE EXTRA MARGIN OF SAFETY BUILT IN

# outside sun visor and traffic light viewer

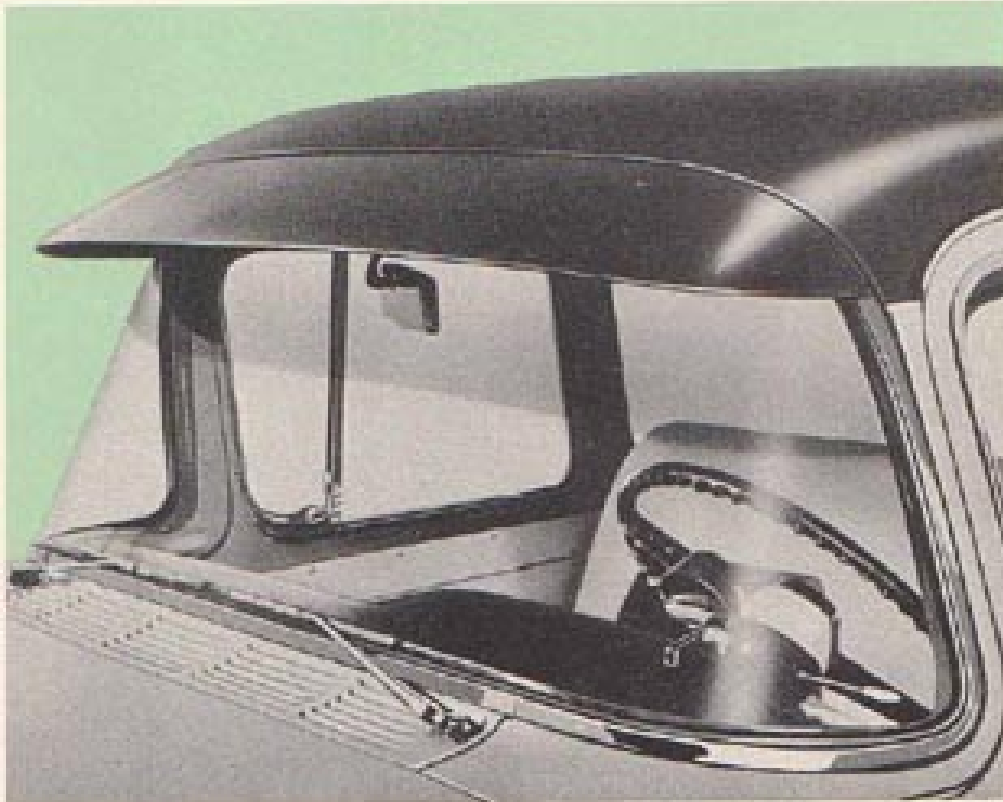

PART NO.	DESCRIPTION	MODEL APPLICATION
2233394	Outside Sun Visor	100 thru 670; F350 thru F600
2233612	Traffic Lite Viewer	All Models

## PRODUCT DATA

A sturdy one piece Sun Visor which affords full protection from snow, ice and sun glare. Mounts directly to the cab roof without the use of brackets . . . eliminates vibration or flutter.

Furnished in prime coat only. Use GMC self spraying lacquer (see page 48) to match visor with truck paint.

## TRAFFIC LIGHT VIEWER

A high quality, optically clear, prismatic viewer affording driver full, clearly reflected view of overhead traffic light when obstructed by top of cab.

FOR A NEW THRILL DRIVE A GMC TRUCK HYDRAMATIC





# windshield washer

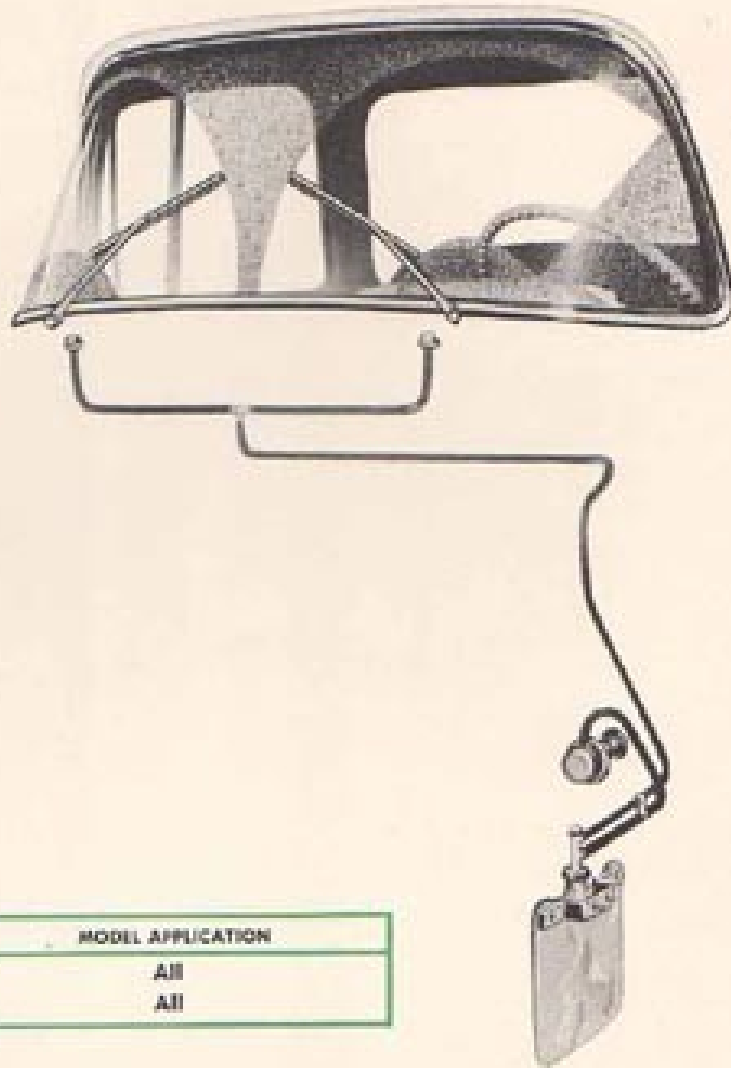

LIT NO.	DESCRIPTION	MODEL APPLICATION
133473	Windshield Washer	All
133472	Solvent, Windshield Washer	All

## PRODUCT DATA

The GMC Windshield Washer is positive in action, and operates independent of the vacuum furnished by the engine. Merely press the foot button and the washer responds, squirting two jet streams of water on the windshield directly in the path of the wiper blades.

This positive flow of water enables the windshield wipers to effectively remove road grime and splash-dirt. The

solvent helps remove bugs and grime more effectively and prevents freezing.

A plastic reservoir is used in place of the usual glass jar to eliminate any possibility of breakage due to freezing, rough roads or misuse in maintenance.

Truly an essential safety accessory for installation on all models including diesel.



FIT RIGHT—LAST LONGER—WITH THE EXTRA MARGIN OF SAFETY BUILT IN

# self spraying lacquer



1954-1955 COLORS	
LACQUER—12 oz. Self Spraying Can Package Quantity—4.	
PART NO.	COLOR
2233532	Delta Green
2233533	Aqua Blue
2233534	Aspen Green
2233535	Seminole Brown
2233536	Panama Cream
2233537	Merlin Blue
2233538	Placid Blue
2233539	Dover White
2233540	Harmony Gray
2233437	Black
2233438	Flame Red
2233434	Leveler, Clear
2233435	Primer
2233439	Omaha Orange
2233440	Chrome Yellow
1954 COLORS	
2233435	Jungle Green
2233436	Cocoa Brown
2233437	Black
2233438	Flame Red
2233439	Teal Blue
2233431	Green, Metallic
2233432	Blue, Metallic
2233433	Tan, Metallic
2233434	Leveler, Clear
2233435	Primer
2233436	Huron Green
2233437	Neptune Green
2233438	Sahara Tan
2233439	Omaha Orange
2233440	Chrome Yellow
2233441	Cumberland Blue

## PRODUCT DATA

Self spraying air dry lacquer is available in colors to match the finish of the new truck. It is invaluable for touch up work and painting service items that are stocked prime only.

It is very easy to use. No expensive equipment is needed and it eliminates mess or clean-up. Complete, easy to follow instructions on the can.

FOR A NEW THRILL DRIVE A GMC TRUCK HYDRAMATIC





GMC TRUCK and COACH DIVISION  
GENERAL MOTORS CORPORATION  
PARTS and ACCESSORIES MERCHANDISING DEPARTMENT