

**GMC**  
TRUCK

# S-15 PICKUPS

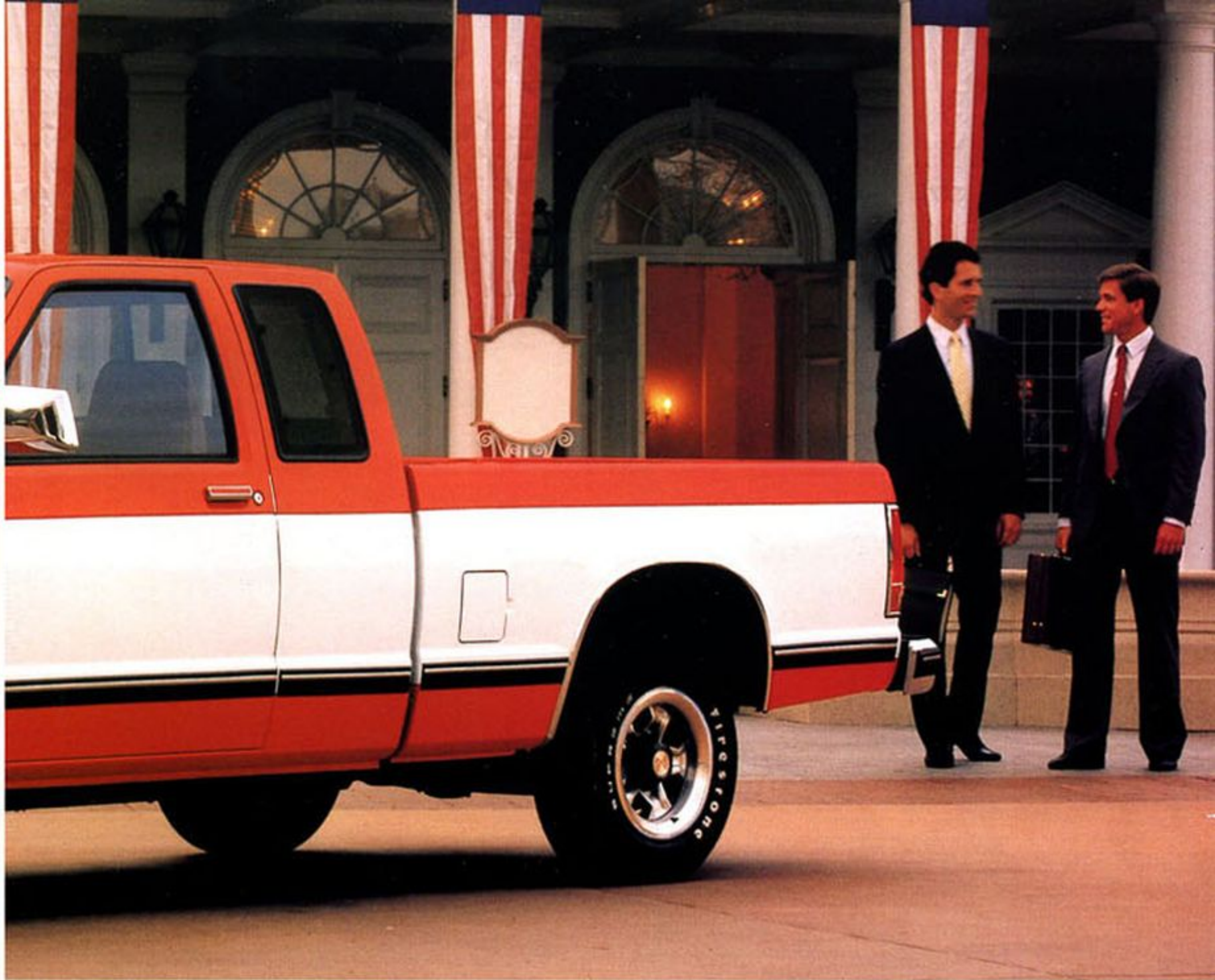



Whether it's for work or play, a GMC Truck S-15 Pickup suits the occasion. 2-WD Sierra Classic Club Coupe shown with available equipment.

**GMC**  
TRUCK

**HIGH-STYLED**

**PERSONAL PICKUP**

Tires are supplied by various manufacturers.

**ECONOMICAL PLEASURE TRUCK**

GMC Truck's S-15 Pickup provides impressive payloads for heavy hauling while meeting today's lifestyle needs. And for many people it's an economical alternative to a car. That's because it's sized right for today's needs. It's bigger than most import pickups so it can carry a lot. It's smaller than a full-size pickup for easy manoeuvrability. And it's roomy and quiet for comfort on long jaunts.

There's a wide choice of S-15 Pickups — 2-WD or 4x4, long 2.26-m (7.42-ft) or short 1.86-m (6.09-ft) cargo box, Regular Cab or Club Coupe, and with V6 or available 4-cylinder gas power on most models.

**WIDE CHOICE OF OPTIONS**

GMC Truck gives you a broad choice of trim levels and options to let you outfit an S-15 to your individual taste. The four trim levels are standard Sierra and available High Sierra, Sierra Classic, and the very sporty Gypsy.

Ten solid exterior colour choices are standard, and three distinctive exterior two-tone colour schemes are available (see page 16). Page 13 illustrates many of the options available on S-15. Standard and available equipment and technical information are found on pages 18-19 of this catalogue.

**'88 IMPROVEMENTS**

The S-15 has several improvements for '88 to add to its value. The 2.8L EFI V6 engine is now standard in most S-15 Pickups, providing you with 125 SAE net horsepower for impressive performance. A 5-speed manual transmission with overdrive is now the standard transmission on all Pickup models, with the 4-speed automatic overdrive being available. A new standard 76-litre (16.7-gallon) fuel tank on most models gives greater driving range. And there's a new inside rearview mirror option with dual reading lamps.



**CLUB COUPE'S EXTRA SPACE**

The Club Coupe gives you extra space inside. Standard are two high-back front bucket seats and two folding jump seats in the rear. That brings standard seating capacity up to four. The front passenger seat conveniently tilts and slides forward for easy access to the rear compartment.

The Club Coupe carries a roomy 1.86-m (6.09-ft) long pickup box on its own 3122 mm (122.9-inch) wheelbase. Payloads are rated at 454 kg (1000 lb) and 680 kg (1500 lb).

**CAB & CHASSIS MODEL**

A 2-WD Regular Cab & Chassis model on a 2995 mm (117.9-in) wheelbase also is available. Rated at 2087 kg (4600 lb) GVW, it comes equipped with standard 2.8L V6 engine and 4-speed manual transmission. Consult your GMC Truck Dealer for further details.

Sierra Classic Club Coupe Interior with Custom Vinyl seat trim



2-WD S-15 Gypsy Club Coupe Pickup shown with available Custom Two-Tone paint.

Tires are supplied by various manufacturers.

# GMC TRUCK GYPSY - SPORT STANDOUT

## DISTINCTIVE STYLING

S-15 Gypsy stands out from other compact pickups with its distinctive styling and tasteful accents. Outside, it has a Sport or Custom Two-Tone paint scheme and contemporary black accents all-around, including black below eye-line mirrors. Rally wheels are included on 2-WD models and cast aluminum wheels are provided on 4-WD units. Front and rear bumpers with rub strips are keyed to the exterior colour.

Inside, Gypsy's striking interior includes high-back bucket seats in your choice of Charcoal or new Saddle Sport Cloth. The Club Coupe Gypsy now offers reclining front buckets and rear jump seats as standard. Genuine leather seat coverings in Saddle or Charcoal are available for the reclining bucket seats on Club Coupe models. Colour-keyed rubber floor covering can be ordered to replace Gypsy's standard carpeting. Front floor mats are standard.

## MORE SPORTY TOUCHES

Gypsy adds to your convenience with a locking console between the seats, map pockets and driver's coin holder in door trim panels, a package tray under the dash, an engine compartment lamp, an exterior cargo area lamp, dual sunshades with a vanity mirror on the right side, an interior rearview mirror with dual reading lamps, and intermittent windshield wipers. The climate control has a deluxe vent system with side window defoggers for good, all-weather visibility. Tinted glass for all windows adds to interior comfort, and Club Coupe rear quarter windows swing out.

Ahead of Gypsy's sport steering wheel is a contemporary instrument panel with full-gauge instrumentation, including trip odometer. An electronically-tuned AM/FM stereo radio with seek/scan feature, digital clock and stereo cassette player is standard. A gutsy V6 gas engine with Electronic Fuel Injection is ready to move you out quickly (2.5L 4-cylinder engine available on 2-WD models).



Gypsy Regular Cab interior with Sport Cloth seat trim



2-WD S-15 Sierra Classic Club Coupe Pickup with Sport Two-Tone paint and other available equipment.

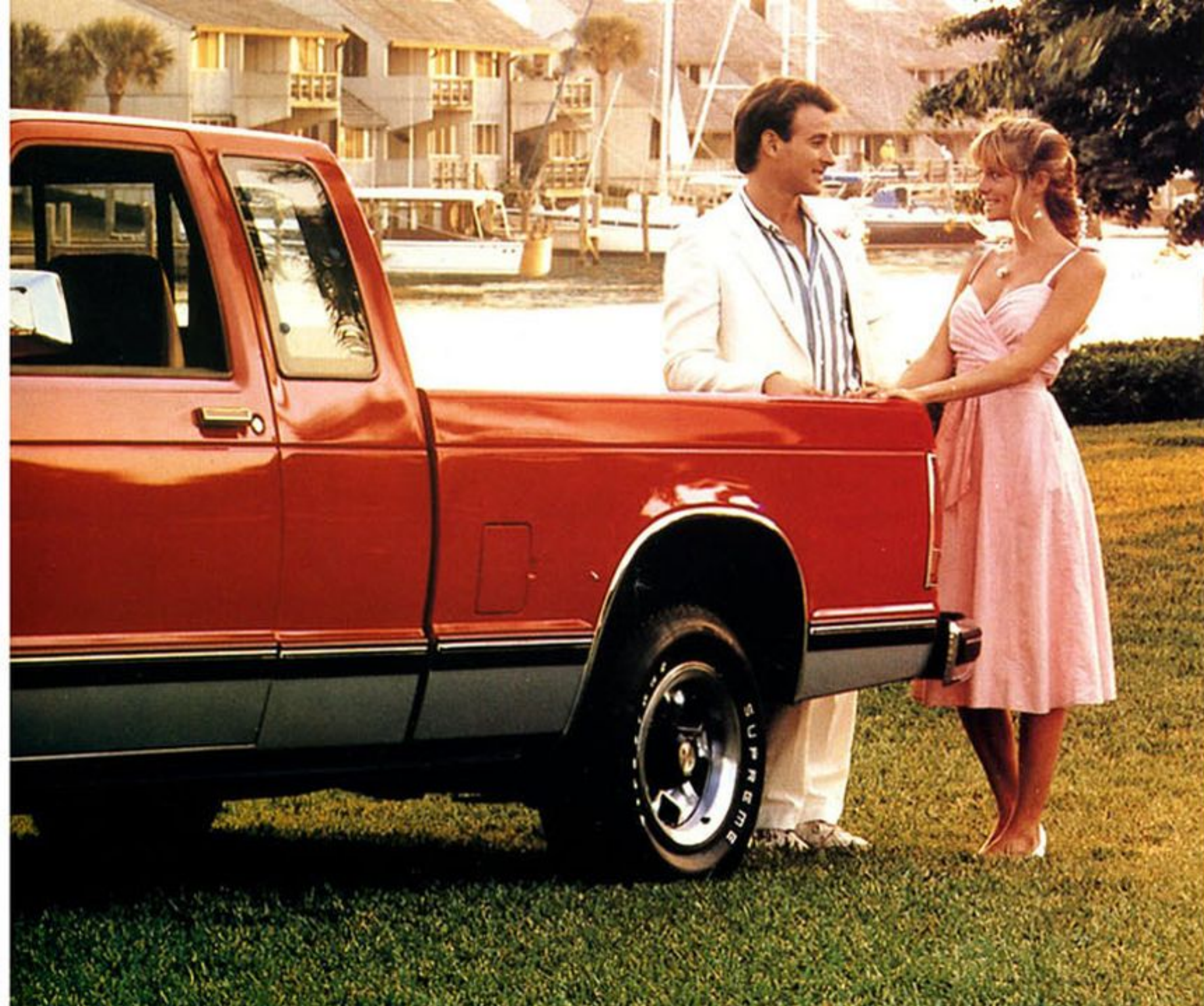

Tires are supplied by various manufacturers.

## GMC SIERRA CLASSIC TRUCK - CITY SLICKER

### CARPETED ELEGANCE

Many people are turning to an S-15 Pickup as a substitute for a car and here's one good reason why: Compare the Sierra Classic interior pictured at the left with that of any well-appointed passenger vehicle; Sierra Classic looks just as stylish and elegant — and it is.

Outside, Sierra Classic has bright trim, black accents, chrome front and rear bumpers with rub strips, and bright below eyeline mirrors.

### CAR-LIKE INTERIOR

Inside, the ambiance is definitely carlike. The seating, full-floor carpeting with front floor mats, and interior trim panels are all colour-coordinated in a choice of four colours. High-back front bucket seats and rear jump seats are standard on the Club Coupe. The Club Coupe also offers available reclining front bucket seats with genuine leather seat coverings.

### MORE LUXURY

The door trim, too, is elegant, with a decorative cloth insert, lower carpeted area, and a map pocket. Also included on Sierra Classic for 1988 are the following: engine compartment lamp, exterior cargo area lamp, inside rearview mirror with dual reading lamps, electronically-tuned AM/FM stereo radio, intermittent windshield wipers, tinted glass all-around, rally wheels with trim rings for 2-WD and cast aluminum wheels for 4-WD, and swing-out rear quarter windows on Club Coupe models. See page 19 for a complete list of standard and available equipment.

If you like tasteful elegance and comfort, you'll feel right at home in the S-15 Sierra Classic.



Sierra Classic Regular Cab interior with standard bench seat and Custom Cloth seat trim



# **GMC** HIGH SIERRA TRUCK - HANDSOME BARGAIN

## **MANY EXTRAS INCLUDED**

The High Sierra trim package adds a number of items of trim and equipment over the standard Sierra Pickup. And the cost is very minimal for a lot more distinction. Outside, 1988 High Sierra adds chrome front and rear bumpers with rub strips, black wheel opening mouldings, tinted windows, black below eyeliner mirrors, rally wheels with trim rings for 2-WD and cast aluminum wheels on 4-WD models, and swing-out rear quarter windows on Club Coupe models for even more value. See page 19 for a complete list of standard and available equipment.

## **ATTRACTIVE INSIDE**

Inside, High Sierra's handsome trim is very pleasing to the eye and colour-coordinated throughout. It includes a bench seat on Regular Cab models. High-back front bucket seats and rear jump seats are standard on Club Coupe models. There's durable rubber floor covering

underfoot and dual sunshades overhead. The deluxe heater/defroster has side window defoggers. The steering wheel is also deluxe. Both the glove box and ashtray are lighted for your convenience. And there's a cigarette lighter and headlamp warning buzzer. An AM monaural radio is standard.

High Sierra puts it all beautifully together with just the right extra touch. Available for Regular Cab units are high-back bucket seats in Custom Vinyl; new Special Custom Cloth trim also is available on high-back bucket seats in the Club Coupe.

## **OTHER MODELS**

See pages 10-11 for information on the standard Sierra S-15 Pickup. There are also specially-priced Sierra S-15 Pickups with specific equipment. See your GMC Truck Dealer for details.

2-WD S-15 High Sierra Regular Cab Pickup shown with Special Two-Tone paint and other available equipment. Tires are supplied by various manufacturers.



4-WD S-15 High Sierra Regular Cab interior shown with standard bench seat and Custom Cloth seat trim



4-WD S-15 Sierra Regular Cab Pickup shown with available equipment. Tires are supplied by various manufacturers.

## **GMC** SIERRA - TOUGH WORKER TRUCK

### **THRIFTY ALTERNATIVE**

If you're looking for a pickup that doesn't cost a lot but can still do a lot of work, consider GMC Truck's standard S-15 Sierra models. They come in a wide variety of model types to handle a surprising number of jobs — with 2-WD or 4x4, Regular Cab or Club Coupe, long or short box, two engines (2-WD models only), two transmissions, a wide rear axle selection, and a wide choice of available wheels and tires.

It's an easy-handling, smooth-riding pickup with a contemporary design. It's built tough, too, with strong components and double-wall construction. And it scores high marks for quality.

### **GOOD PAYLOADS**

S-15 is available with four payload ratings: 454 and 680 kg (1000 and 1500 lb) with both 2-WD and 4x4 and 737 kg (1625 lb) and — new for '88 — 907 kg (2000 lb) with 2-WD Regular Cab only. S-15 delivers. And it can tow up to 2268 kg (5000 lb) when properly equipped.

### **STANDARD SIERRA**

The standard Sierra S-15 Pickup comes functionally equipped with AM monaural radio, halogen headlamps, full-size spare tire mounted on winch-operated carrier, black front bumper and matching rear step bumper, dome and courtesy lights, locking glove box, and parcel tray. High-back front bucket seats and rear jump seats are standard on the Club Coupe.



2-WD S-15 Sierra Regular Cab interior shown with standard bench seat and Standard Vinyl seat trim



4-WD S-15 Sierra Classic Club Coupe Pickup with standard Insta-Trac 4-wheel drive system. Shown with available equipment. Tires are supplied by various manufacturers.

### SIMPLE SHIFT-ON-THE-FLY

GMC Truck's Insta-Trac is a simple, tough, state-of-the-art 4-wheel drive system that enables you to easily utilize the full potential of your S-15 Pickup for work or for fun and adventure. This GM patented system lets you shift from 2 WHEEL to 4 HIGH or back again on the fly, at any speed. You don't have to get out of the truck to lock or unlock wheel hubs. Insta-Trac is a simpler 4-WD system with fewer moving parts than those using locking front wheel hubs.

### INDEPENDENT FRONT SUSPENSION

4-WD S-15 Pickups feature an independent front suspension that's smooth riding because one wheel's action has minimal effect on the other. Just as important, you have better tire-to-ground contact for excellent 4x4 traction and vehicle control. Torsion bar suspension, power brakes and front stabilizer bar are all standard. For '88 the powerful 2.8L EFI V6 gas engine also is standard on all 4-WD models. Ground clearance is excellent, too, with a 175 mm (6.9-in) minimum clearance. Yet the cab is close enough to the ground for easy entry and exit.

### OFF-ROAD PACKAGE

An off-road package is available that includes: stone shields for fuel tank and transfer case, special Delco/Bilstein gas shock absorbers, special torsion bars, special front stabilizer bar, bigger jounce bumpers, front tow hooks, and P235/75R15 tires.

Shift the floor-mounted transfer case lever from 2 WHEEL to 4 HIGH and back again at any speed



Display lights up to indicate what mode you're driving in

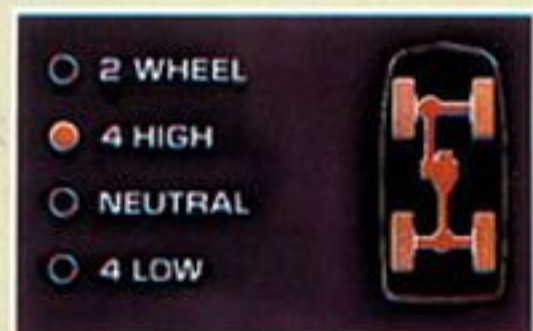

# QUALITY OPTIONS

## AVAILABLE EQUIPMENT AND ACCESSORIES

In addition to those items illustrated below equipment includes:  Rearview mirror with map lights  Body striping: Regular, Sunshine, or Rally  Front stabilizer bar  HD front/rear shock absorbers  Locking rear axle differential  Engine block heater  4x4 transfer case/

fuel tank shields  HD battery  HD radiator  HD transmission oil cooler  Cold climate package  4x4 tow hooks  4x4 off-road package. Not all items are available on all models. See your GMC Truck Dealer for details and for other items as well as dealer-installed accessories.

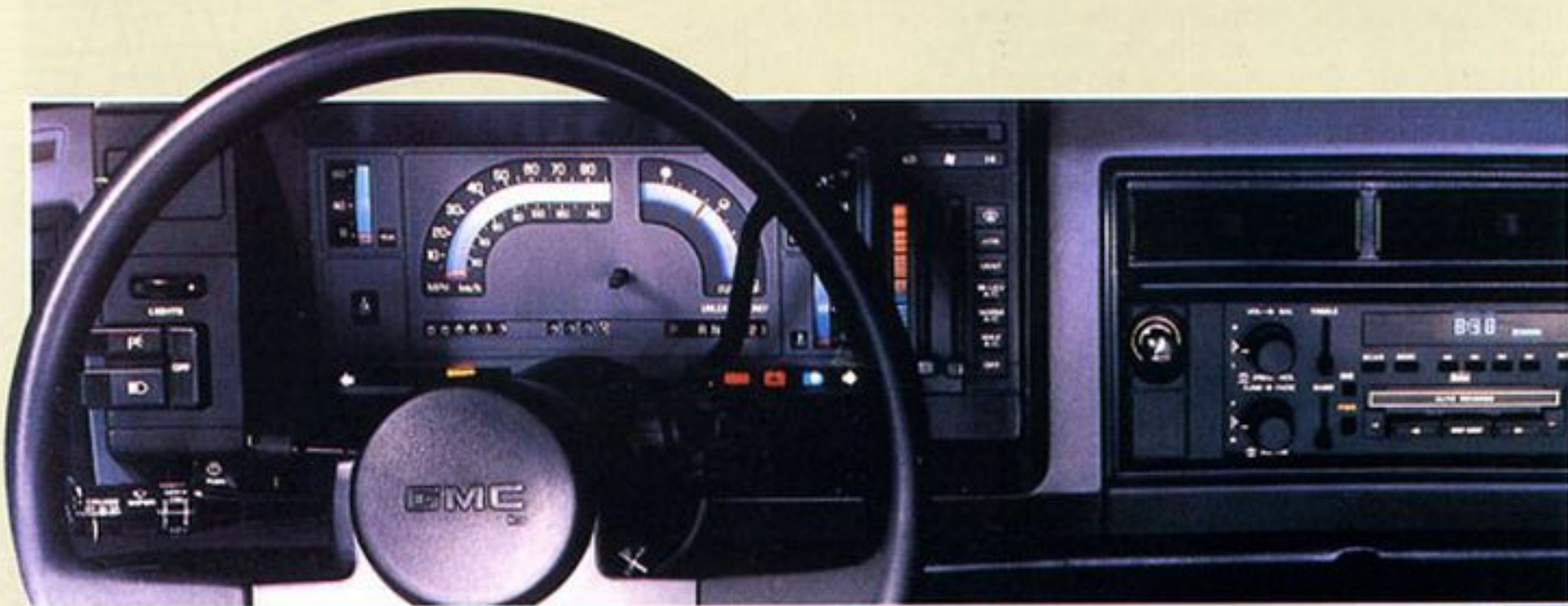

Electronic speed control, intermittent windshield wipers\*, air conditioning, AM/FM stereo radio with seek/scan, clock, and cassette player\*  
Note: Instruments are metric in Canada.



Left to right: Comfortilt steering wheel, Club Coupe reclining bucket seat\*, power door locks and power windows



Left to right: Sliding rear window, Exterior cargo lamp\*,



Left to right: Below eyeline mirrors\*, rally wheels\*, aluminum wheels\*

Tires are supplied by various manufacturers.

\* Standard on selected models. See your GMC Truck Dealer for details.



# GMC TRUCK CONSISTENT HIGH QUALITY

## GMC TRUCK'S COMMITMENT TO BE THE BEST

S-15 was one of the first programs that reflected GMC Truck's determination to make its vehicles the best in their particular class. Right from the start, GM engineering, design, manufacturing and assembly staffs, plus GM's suppliers worked closely together to assure world class quality. The result: S-15 has consistently earned some of the highest scores in GM's quality audit program. It's the kind of quality that's paid off with satisfied customers.

**The latest technologies** in computer design, robotics, and lasers are used for S-15. Most important, quality is an ongoing process at GMC Truck involving the entire staff. The new technology is constantly being reviewed, refined and improved.

**Double-wall construction** is used in the hood, front fenders, side doors, part of cab back panel, pickup box sides, tailgate, and Club Coupe rear quarter panels.

**Large single-piece stampings** for major body panels eliminate many coach joints and reduce the possibility of corrosion. One-piece door frames and door panels and welded-on hinges provide excellent fit of doors.

**Concealed drip mouldings** add to vehicle looks and aerodynamics.

**Tough, full-frame of carbon steel** has welded front box section and open channel rear section to provide good support for cab, pickup box, front suspension and drivetrain.

**Good choice of rear axle ratios** for various applications, with limited slip differential available with most ratios. Two-stage multileaf rear springs adjust to load for smooth ride.

**Independent front suspension** with coil springs on 2-WD, torsion bars on 4x4. Provides excellent ride and good contact with road, especially for 4x4 traction.

**Front disc brakes, rear drum brakes.** New front brake lining insulators assure quiet operation. Power brakes are standard on all S-15 Pickups.

**Large fuel tank** of 76-litre (16.7-gallon) capacity, formerly optional, is now standard on most models, replacing the former 50-litre (11-gallon) tank for increased driving range.

**High-capacity Delcotron generator** with 85-amp output is standard, along with high-output standard and available Delco Freedom II+ batteries that never need addition of water.

**Deluxe heater system**, standard on all except Sierra models, includes side window defoggers. Standard flow-through ventilation exhausts stale air through door vents.

**Folding front seat back** on Regular Cab tilts forward for access to storage space behind seat.

**Anti-corrosion measures:** □ Coated steels for most body parts □ 8-stage zinc phosphate wash system □ Cathodic Elpo Dip primer □ Anti-chip coating on rocker panels □ Wax coating in door cavities and on frame, front stabilizer bar, rear axle, and rear springs □ Primer and finish acrylic enamel film build of 3.1 mils

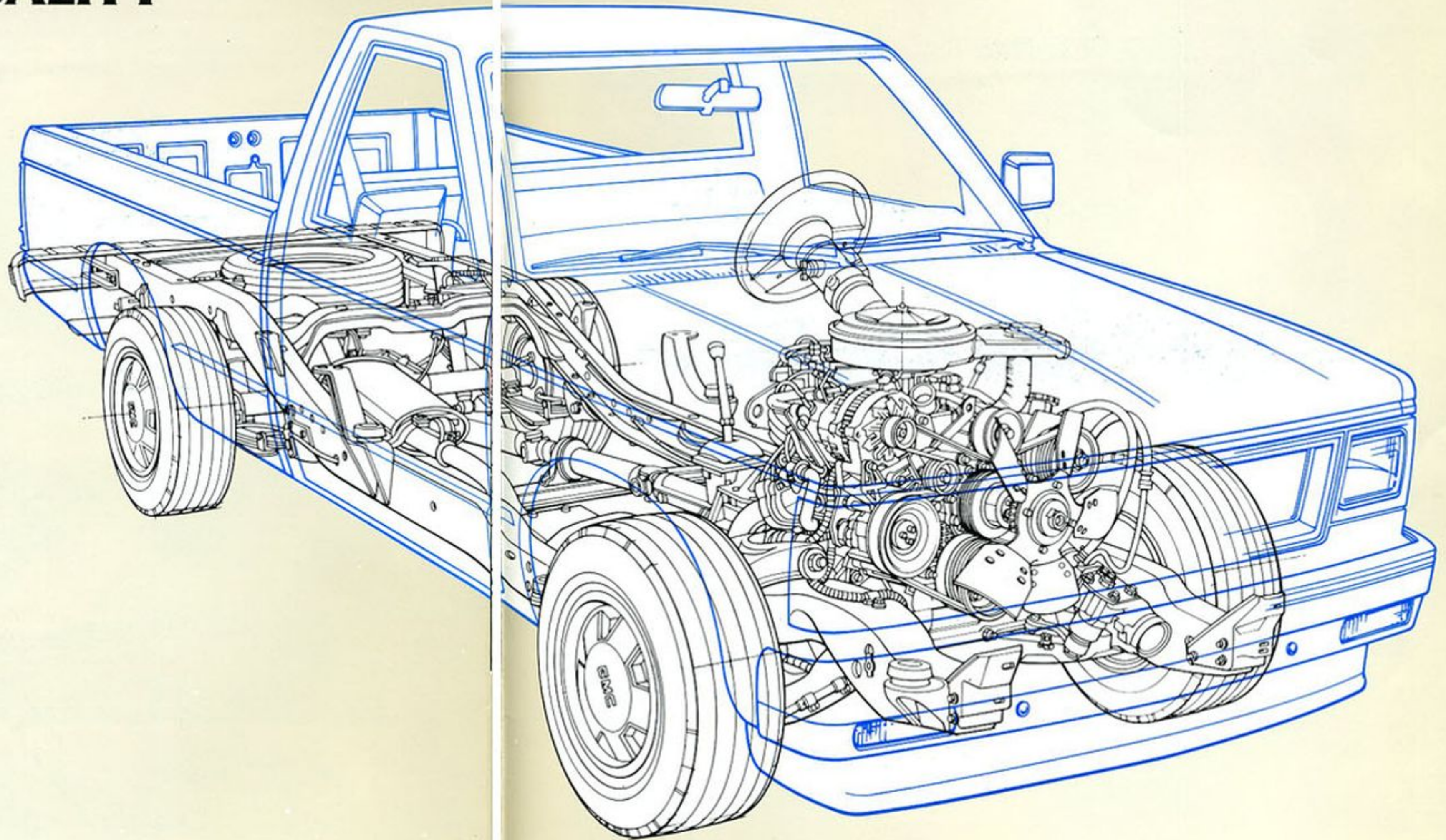

Anti-corrosion measures

Front disc brakes

Flow-through ventilation

Concealed drip moldings

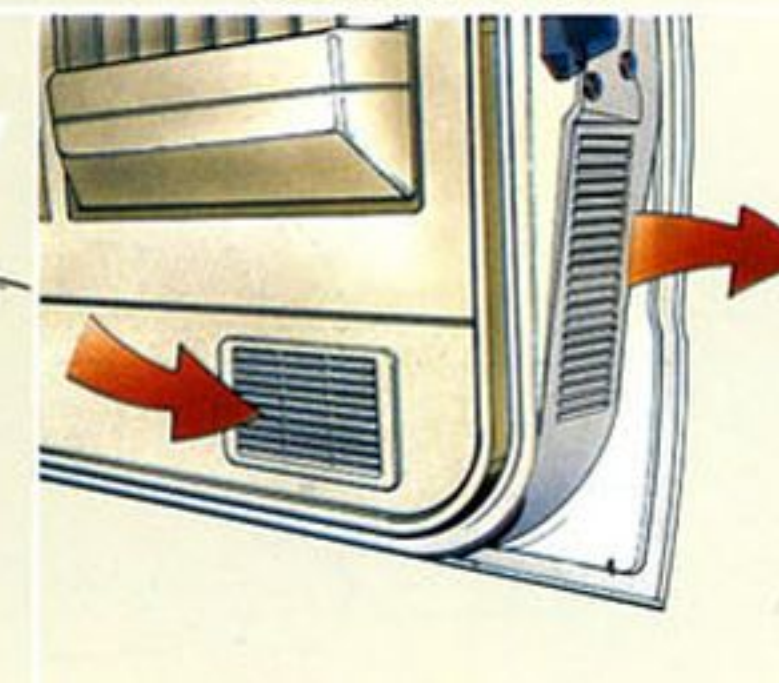
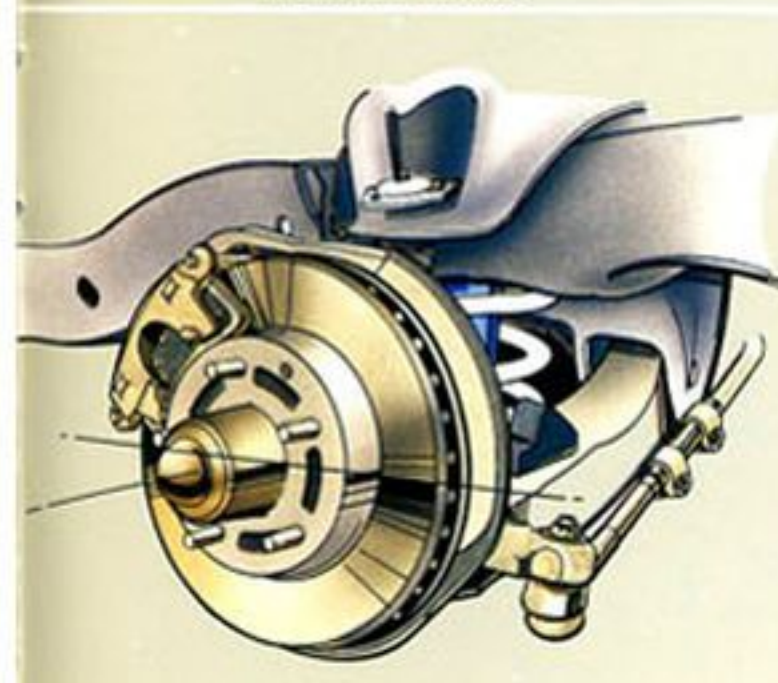
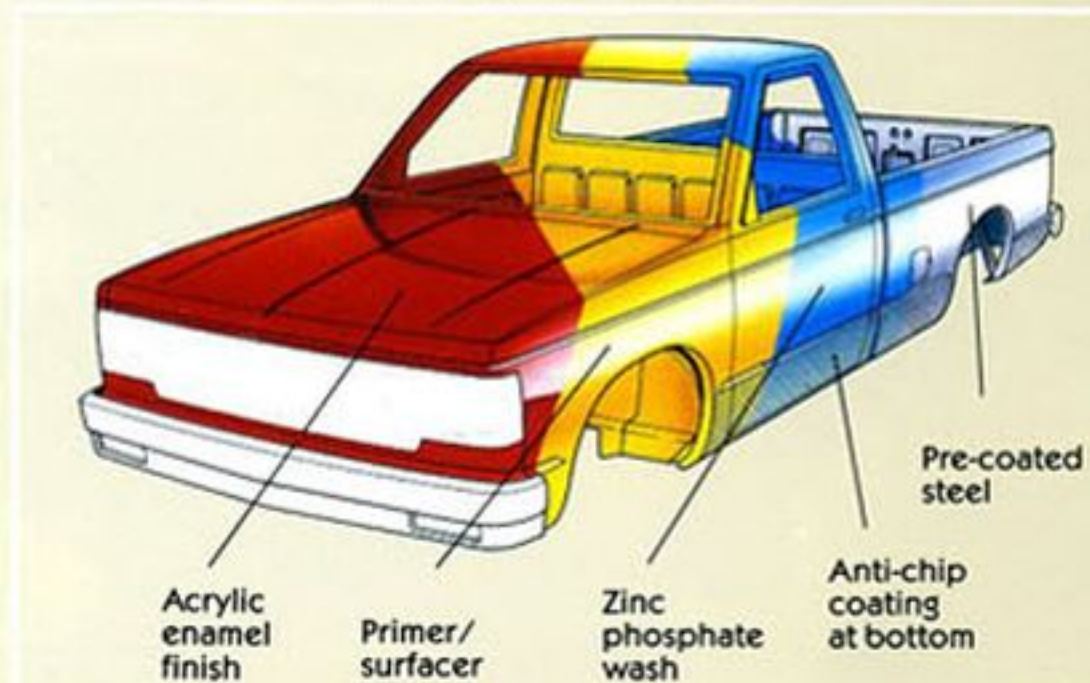

# GMC TRAILERING TRUCK

2-WD S-15 Sierra Classic Regular Cab Pickup with Trailering Special and other equipment



## TRAILERING

A properly equipped S-15 Pickup with 2.8 Litre V6 engine can move up to 3856 kg (8500 lb) Gross Combination Weight — that includes everything going down the road (truck, trailer, passengers, cargo, and equipment on truck and trailer). See chart below.

To help you properly equip your S-15 Pickup for trailering, you can order from the factory a Heavy-Duty Trailering Special Equipment package (Z82) that permits towing trailers up to 2268 kg (5000 lb) gross weight, including trailer, equipment, and cargo (weight of cargo in pickup box must be deducted from allowable gross trailer weight). For complete details about Z82 plus recommendations and requirements for heavy-duty or light-duty trailering, ask your GMC Truck Dealer for a 1988 Truck Trailering Guide.

## GROSS COMBINATION WEIGHT RATING BY ENGINE AND AXLE RATIO FOR AUTOMATIC TRANSMISSIONS

ENGINE	GROSS COMBINATION WEIGHT RATING, kg (lb)				
	2722 (6000)	2948 (6500)	3175 (7000)	3402 (7500)	3856 (8500)
	REAR AXLE RATIO				
2.5L I4 GAS	3.73	4.11	—	—	—
2.8L V6 GAS	—	—	3.42	3.73 (1) 4.11 (1)(2)	3.73 (1) 4.11 (1)(2)

1 - Requires Z82 trailering equipment.

2 - Requires P235/75R-15 tires.

## EXTERIOR COLOURS

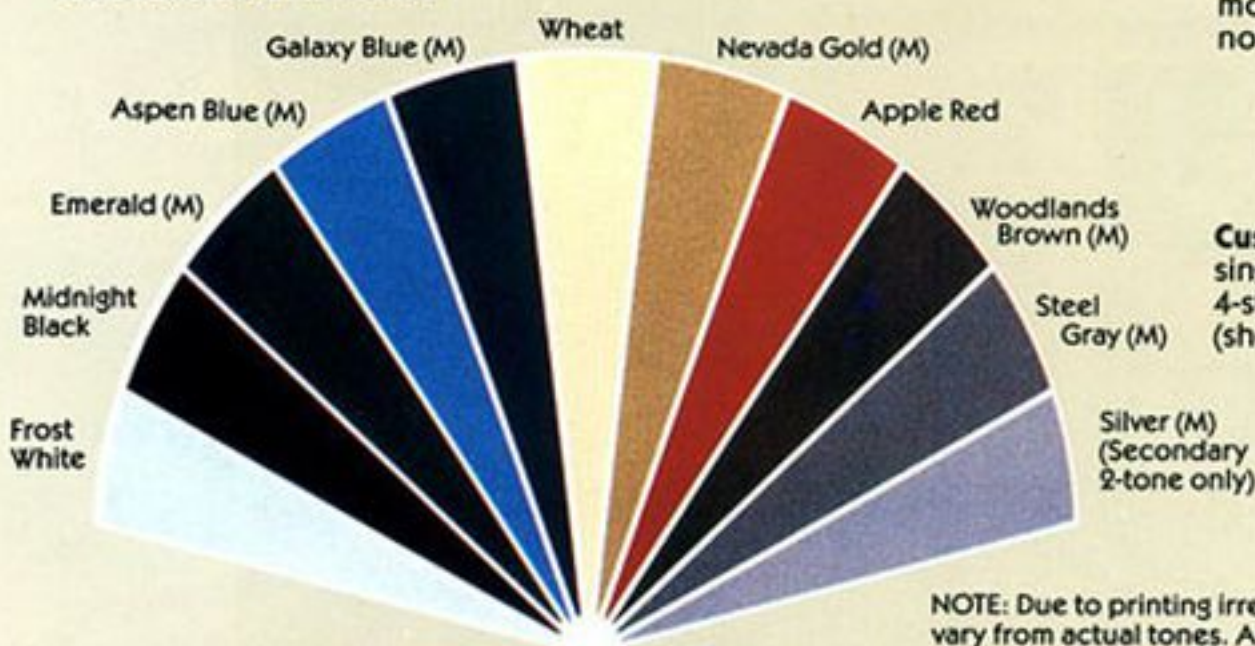

NOTE: Due to printing irregularities, colours shown may vary from actual tones. Ask your dealer to show you actual paint chips and fabric swatches. (M) = Metallic.

## PICKUP PAINT SCHEMES

**Solid Colour** is standard on all models except Gypsy. Three types of striping are available: Regular (4-stripe), Sunshine (4-stripe, as shown), and Rally (6-stripe).



**Sport Two-Tone.** Lower accent colour stretches around to front and rear bumpers.



**Special Two-Tone** extends middle accent colour around front and rear. Body side and wheel opening mouldings included where not standard to the model.



**Custom Two-Tone** includes single upper decal striping. 4-stripe Sunshine striping (shown) is available.



# IMPROVED POWER

## UP-TO-DATE ENGINES

Both the 2.8L V6 and the 2.5L 4-cylinder are contemporary design engines that are constantly being improved. Both have Electronic Fuel Injection for excellent efficiency, smooth response, and easy starting. Both have a single, serpentine accessory drive belt that self-adjusts for long life.

### 2.5 LITRE EFI TECH IV ENGINE

This rugged, in-line 4-cylinder engine with Electronic Fuel Injection is available on 2-WD S-15 Pickups. It's a strong, proven, cast-iron workhorse that delivers impressive horsepower and torque.

### 2.8 LITRE EFI V6 ENGINE

This modern V6 is standard on most S-15 models. Improvements for '88 include a new catalytic converter with honeycomb-shaped catalytic element. Also, an engine oil cooler is now available for the V6 engine in 4x4 applications as part of the Trailering Equipment option (Z82) when the 4.11 axle ratio is specified, permitting an increase in 4-WD vehicle maximum towing capacity from 1814 kg (4000 lb) to 2268 kg (5000 lb).

## A WORD ABOUT ENGINES

GMC Trucks are equipped with engines produced at facilities operated by GM car and truck groups, subsidiaries, or affiliated companies worldwide.

## ENGINE TECHNICAL DATA

TYPE	GASOLINE	
	2.5L (151 CID)	2.8L (173 CID)
Displacement	2.5L (151 CID)	2.8L (173 CID)
Configuration	L4	V6
Ordering Code	LN8	LL2 (1)
Bore and Stroke, mm (in)	101.6 x 76.2 (4.0 x 3.0)	89 x 76 (3.50 x 2.99)
Compression Ratio	8.3 to 1	8.9 to 1
Fuel Delivery	Electronic Fuel Injection	
SAE Net Horsepower @ RPM	92 @ 4400	125 @ 4800
SAE Net Torque (lb/ft) @ RPM	130 @ 3200	150 @ 2400
V.I.N. +	E	H

1 - Not available on some models.

+ The V.I.N. (Vehicle Identification Number) Engine Code is the eighth entry (letter or numeral) from the left on the vehicle serial number plate. The vehicle serial number plate is located on the top portion of the driver's side of the instrument panel and can be viewed from the exterior of the vehicle by looking through the windshield.

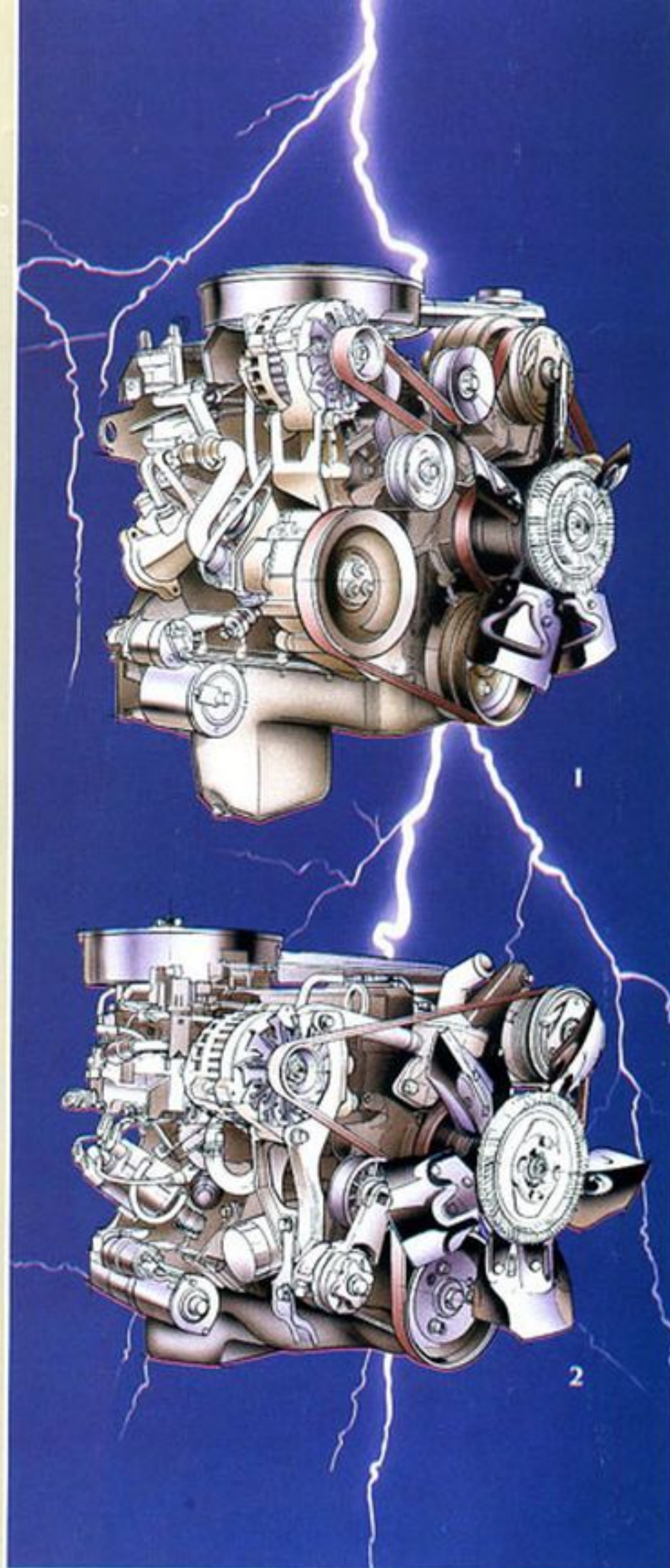

1. Standard 2.8L EFI V6  
2. Available 2.5L EFI Tech IV (2-WD only)

## EASY-SHIFTING TRANSMISSIONS

### 5-SPEED MANUAL OVERDRIVE

A highly efficient transmission with an overdrive gear for impressive fuel economy and less engine wear. For '88, it's standard on all S-15 Pickups.

### 4-SPEED AUTOMATIC OVERDRIVE

This automatic transmission with overdrive gear is available on most S-15 models.



Shift lever for Pickup standard 5-speed manual transmission

PICKUP MODEL TYPE	2-WHEEL DRIVE				4-WHEEL DRIVE (1)	
	PAYLOAD RATING, kg (lb)	454 (1000)	680 (1500) (1)	737 (1625) (1) (2)	907 (2000) (10)	454 (1000)
ENGINE/TRANSMISSION AVAILABILITY	(consult your GMC Truck Dealer for available axle ratios)					
2.5L I4/5-speed manual overdrive	available (3)	available	available	—	—	—
2.5L I4/4-speed automatic overdrive	available (1)	available	available	—	—	—
2.8L V6/5-speed manual overdrive	standard (1)	standard	standard	standard	standard	standard
2.8L V6/4-speed automatic overdrive	available (1)	available	available	—	available	available
FRONT SUSPENSION	independent, coil springs				independent, torsion bars	
Capacity, kg (lb)	1134 (2500)	1134 (2500)	1134 (2500)	1134 (2500)	1224 (2700)	1224 (2700)
Spring/torsion bar capacity, kg (lb) (4)	567 (1250)	567 (1250)	567 (1250)	567 (1250)	612 (1350)	612 (1350)
Shock absorber diameter, mm (in)	standard: 25 (1.0); available: 32 (1.26)					
Stabilizer bar diameter, mm (in)	avail: 32 (1.26) (9)	std: 32 (1.26)	std: 32 (1.26)	std: 32 (1.26)	std: 32 (1.26)	std: 32 (1.26)
REAR SUSPENSION	Salisbury axle, leaf springs				Salisbury axle, leaf springs	
Axle capacity, kg (lb)	1179 (2600)	1179 (2600)	1179 (2600)	1179 (2600)	1224 (2700)	1224 (2700)
Spring capacity, kg (lb) (4)	592 (1150)	612 (1350)	612 (1350)	612 (1350)	592 (1150)	612 (1350)
Shock absorber diameter, mm (in)	standard: 25 (1.0); available: 32 (1.26)					
BRAKES	hydraulic, front disc/rear drum					
Vacuum booster	standard					
Parking	cable to rear wheels					
STEERING	Standard	power (1)	power			
TIRES, RADIAL-PLY	Standard (6)	P195/75R-14 (5)	P195/75R-14	P205/75R-14	P205/75R-14	P205/75R-15
	Available	various (consult your GMC Truck Dealer) (8)				
FUEL TANK CAPACITY, litres (gallons)	76 (16.7) (7)					
FREEDOM BATTERY CCA	standard: 525 (2.8L V6)/630 (2.5L I4); available: 630 (2.8L V6)					
GENERATOR AMPS	85					

CCA = Cold Cranking Amps  
 1 - Not available on X81 Special and X96 Regular Pickup models.  
 2 - Regular Cab models only.  
 3 - Standard for X81 Special and X96 Regular Pickup models.  
 4 - At ground, each.  
 5 - RPO X81 Special Pickup: compact spare; RPO X96 Regular Pickup: P205/75R-14 tires and full-size spare.  
 6 - All Seasons type.  
 7 - For X81 Special Pickup 50-litre (11-gallon) fuel tank is standard.  
 8 - Tire chains should not be used with available P235/75R tires as they may cause damage to the vehicle.  
 9 - Not available on X81 Special Pickup.  
 10 - Long-wheelbase Regular models only.

## DIMENSIONAL DATA NOTE: All dimensions shown in inches.

Short-Wheelbase Regular Cab Pickup

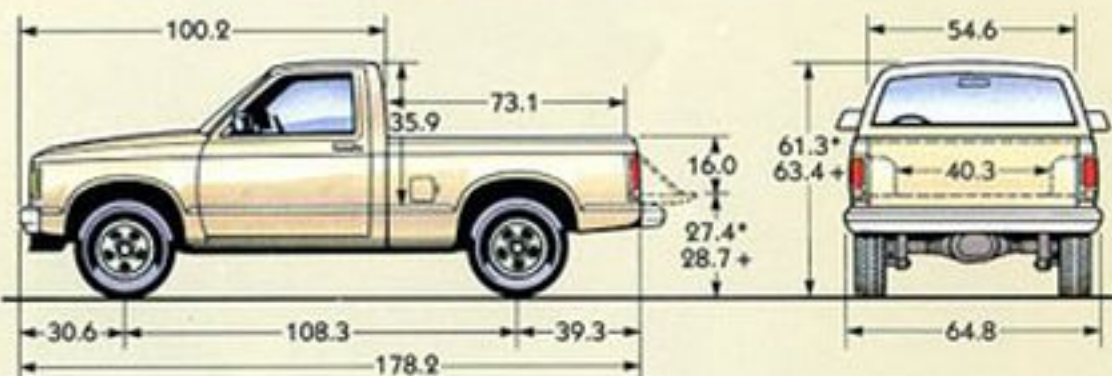

Club Coupe Pickup

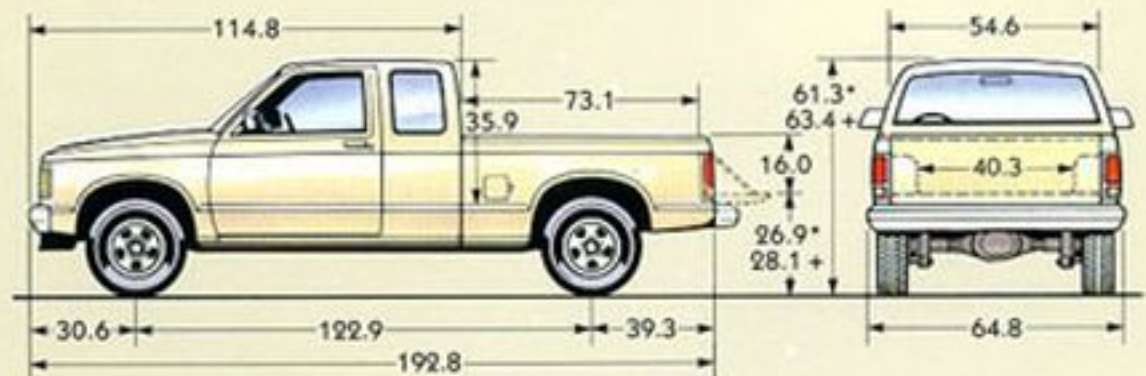

Long-Wheelbase Regular Cab Pickup

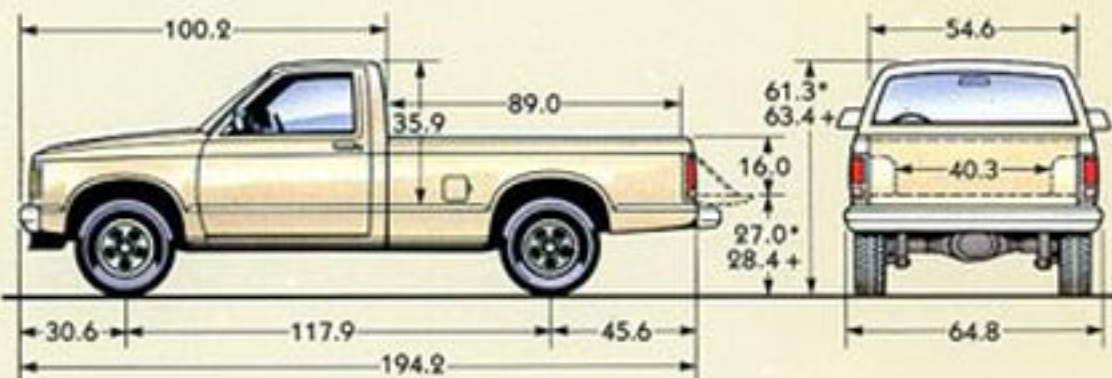

Cab & Chassis

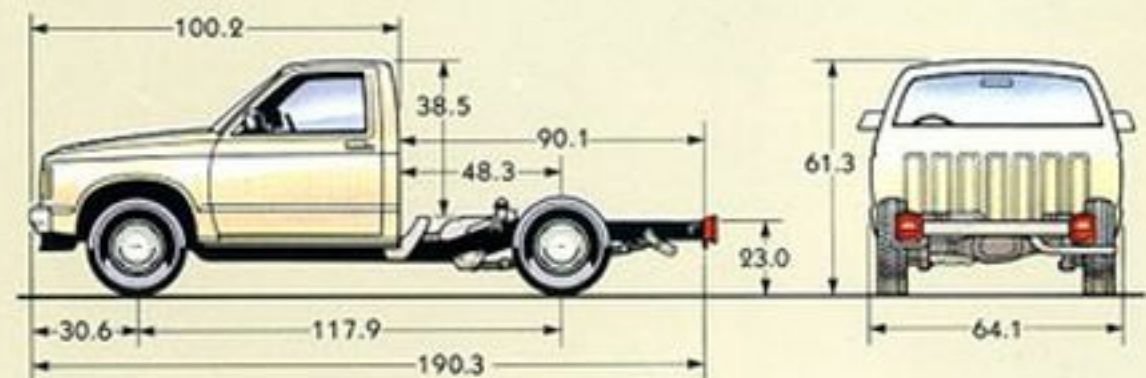

\* 2-Wheel Drive  
 + 4-Wheel Drive

## S-15 PICKUP AND CAB & CHASSIS MODEL AVAILABILITY

MODEL TYPE	BODY TYPE	MODEL NUMBER	WHEELBASE, mm (in)	PAYLOAD RATING, kg (lb)
2-Wheel Drive	2-Door Regular Cab Pickup	TS10603/X81 (1)	2750 (108.3)	454 (1000)
		TS10603/X96 (2)	2750 (108.3)	454 (1000)
		TS10603/ZE5 (3)	2750 (108.3)	454 (1000), 680 (1500), 737 (1625)
	TS10803	2995 (117.9)	454 (1000), 680 (1500), 737 (1625), 907 (2000)	
4-Wheel Drive	2-Door Club Coupe Pickup	TS10653	3122 (122.9)	454 (1000), 680 (1500)
	2-Door Regular Cab & Chassis	TS10803	2995 (117.9)	GVWR: 2087 (4600)
	2-Door Regular Cab Pickup	TT10603	2750 (108.3)	454 (1000), 680 (1500)
		TT10803	2995 (117.9)	454 (1000), 680 (1500)
	2-Door Club Coupe Pickup	TT10653	3122 (122.9)	454 (1000), 680 (1500)

1-Special Model (Price Leader)    2-Regular Model    3-Standard Model

## STANDARD AND AVAILABLE EQUIPMENT

TRIM LEVEL		SIERRA	HIGH SIERRA (YC1)	SIERRA CLASSIC (YC2)	GYPSY (YC3)
<b>EXTERIOR EQUIPMENT</b>					
APPLIQUE, TAILGATE	Black with integral red GMC letters	—	—	S	S
BUMPER, FRONT	Black painted	S 8	—	—	—
	Chromed with rub strip	—	S	S	—
	Colour-keyed painted with rub strip	A 7,9	A	A	S
BUMPER, REAR STEP-TYPE	Black painted with step pad	S 3	—	—	—
	Chromed with rub strip and step pad	—	S	S	—
	Colour-keyed painted with rub strip and step pad (1)	A 7,9	A	A	S
CARRIER, WINCH-TYPE SPARE TIRE		S	S	S	S
DOOR HANDLES/ LOCK CYLINDERS	Black chrome finish	—	—	—	S
	Bright chrome finish	S	S	S 2	—
GLASS	Deep-tinted	A 7	A	A	A
	Regular-tinted	A 7,11	S	S	S
	Sliding rear window	A 3	A	A	A
	Swing-out Club Coupe rear quarter window	—	S	S	S
GRILLE/ FRONT LAMP BEZELS	Argent paint/bright chrome	S	—	—	—
	Bright chrome/bright chrome	—	S	S	—
	Black chrome/black chrome	—	—	—	S
GUARDS	Bright door edge	A 3	A	A	A
HEADLAMPS	Halogen-type	S	S	S	S
HORN, SINGLE ELECTRIC LOW-NOTE		S	S	S	S
LAMP	Cargo area	A 3	A	S	S
	Engine compartment	—	—	S	S
MIRRORS, DUAL REARVIEW	Black below eyeline	A	S	—	S
	Black conventional	S	—	—	—
	Bright below eyeline	A 3	A	S	—
MOULDINGS	Black body side	A 3	A	S	S
	Black wheel opening	A 3	S	A	S
	Black windshield	S	S	S	S
	Bright wheel opening	A 3,4	A 4	S	—
NAMEPLATE	S-15/trim level front fender	S	S	S	S
	Engine front end	S	S	S	S
	4x4 cab side (4-WD only)	S	S	S	S
SPARE TIRE	Full-size	S 7	S	S	S
TAILGATE DECAL	Red GMC letters	S	S	—	—
TAILLAMP TRIM	Black	—	—	—	S
	Bright	—	S	S	—
WHEELS, CAST ALUMINUM (4-WD only)		A	S	S	S
WHEELS/WHEEL TRIM, 2-WD CONVENTIONAL	Argent with bright hubcaps	S 8	—	—	—
WHEELS/WHEEL TRIM, 4-WD CONVENTIONAL	Argent with black hubcaps	S	—	—	—
WHEELS, RALLY (2-WD only)	Argent with black hubs and bright trim rings	A 9	S	S	S
WINDSHIELD WIPER/WASHER SYSTEM	Conventional	S	S	—	—
	Intermittent	A 3	A	S	S
<b>INTERIOR EQUIPMENT</b>					
AIR CONDITIONING		A 3	A	A	A
ARMRESTS, FRONT DOOR		S	S	S	S
CLOCK, ELECTRIC DIGITAL		A 3,5	A 5	A 5	S
COAT HOOK, RH		S	S	S	S
COLD CLIMATE PACKAGE		A 3	A	A	A
CONSOLE, FLOOR-MOUNTED STORAGE		A 3	S 11	S 11	S

S - Standard  
A - Available  
1 - Must match front bumper.

2 - Includes body colour insert for door handles.  
3 - Except X81 Special and X96 Regular Pickups.  
4 - Part of B84 mouldings.

5 - Integral with selected radios.  
6 - Includes cab back panel.  
7 - Except X81 Special Pickup.

8 - Except X96 Regular Pickup.  
9 - Standard on X96 Regular Pickup.  
10 - Includes door switches.

11 - Standard on Club Coupe.

TRIM LEVEL		SIERRA	HIGH SIERRA (YC1)	SIERRA CLASSIC (YC2)	GYPSY (YC3)
<b>INTERIOR EQUIPMENT (cont'd)</b>					
CONVENIENCE TRAY		S	S	S	S
FLOOR COVERING	Black rubber	S	—	—	—
	Color-keyed carpet, full-length	—	—	S 6	S 6
	Color-keyed rubber, full-length	—	S	A	A
FLOOR MATS, FRONT (with carpeting only)		—	—	S	S
FLOW-THROUGH VENTILATION		S	S	S	S
GRAB HANDLE, RH FRONT DOOR (4-WD only)		S	S	S	S
HEADLAMP WARNING BUZZER		—	S	S	S
HEADLINER		S	S	S	S
HEATER/DEFOGGER	Conventional	S	—	—	—
	Deluxe	—	S	S	S
INSTRUMENT CLUSTER	Gauge-type with tachometer	A 7	A	A	A
	Gauge-type without tachometer	—	S	S	S
	Warning light-type	S	—	—	—
LAMP	Ashtray	—	S	S	S
	Dome and courtesy	S	S 10	S 10	S 10
	Storage compartment, instrument panel	—	S	S	S
LIGHTER, CIGARETTE		A 7,9	S	S	S
MIRROR	Rearview without map lights	S	S	—	—
	Rearview with map lights	A 3	A	S	S
	Right-hand visor	—	—	S	S
NAMEPLATE, TRIM LEVEL		S	S	S	S
OPERATING CONVENIENCE PACKAGE (power door locks/windows)		A 3	A	A	A
RADIOS	AM monaural	S 3	S	—	—
	AM/FM stereo	A 3	A	S	—
	AM/FM stereo with seek/scan, clock	A 3	A	A	—
	AM/FM stereo with seek/scan, clock, stereo cassette	A 3	A	A	S
	AM stereo/FM stereo full-feature	A 3	A	A	A
SEAT	Folding back front bench, Regular Cab	S	S	S	—
	High-back front bucket, Reg. Cab LH/RH	A 3	A	A	S
	High-back front bucket, Club Coupe LH/RH	S	S	S	S
	Club Coupe rear jump, LH/RH	S	S	S	S
SEAT BACK, BUCKET	Easy-entry feature (Club Coupe passenger seat)	S	S	S	S
	Folding feature	S	S	S	S
	Reclining feature (Club Coupe only)	A	A	A	S
STEERING WHEEL	Comfortilt feature	A 3	A	A	A
	Deluxe type	—	S	S	—
	Sport type	—	—	—	S
	Standard type	S	—	—	—
STORAGE COMPARTMENT, INSTRUMENT PANEL		S	S	S	S
SUNSHADES	LH/RH	S	S	S	S
TRIM PANELS, DOOR	Carpet trim	—	—	S	S
	Cloth inserts	—	—	S	S
	Coin holder, LH	—	—	S	S
	Map pockets	S	S	S	S
TRIM PANELS, CLUB COUPE REAR QUARTER		S	S	S	S
<b>OTHER EQUIPMENT (consult your GMC Truck Dealer for details)</b>					

**A WORD ABOUT ASSEMBLY, COMPONENTS, AND OPTIONAL EQUIPMENT IN THESE GMC TRUCK PRODUCTS:** The GMC Trucks described in this brochure are assembled at various divisions of General Motors Corporation. These vehicles incorporate thousands of different components produced by General Motors of Canada Limited and related companies and their suppliers. From time to time during the manufacturing process, it may be necessary, in order to meet public demand for particular vehicles or equipment, or to meet federally mandated emission and safety requirements or fuel economy guidelines, or for other reasons, to produce vehicles with different components or differently sourced components than initially scheduled. All such components have been approved for use in our products by General Motors of Canada Limited or related companies and will provide the quality performance associated with our name. Please note that certain optional equipment can be ordered only in conjunction with other optional equipment.

Also, upgrading from specified standard equipment may be necessary when certain optional equipment is ordered. Ask your sales representative for details.

With respect to extra-cost optional equipment, make certain you specify the type of equipment you desire on your vehicle when ordering it from your dealer. Some options may be unavailable when your truck is built. Your dealer receives advice regarding the current availability of options. You may ask the dealer for this information. GMC Truck also requests the dealer to advise you if an option you ordered is unavailable. We suggest that you verify that your truck includes the optional equipment you ordered, or if there are changes, that they are acceptable to you.

These vehicles also are available under the Chevrolet nameplate as the S-10 Pickup, S-10 Maxi-Cab Pickup, and S-10 Chassis-Cab.

## STANDARD VALUE FEATURES

- Delco Freedom II+ battery never needs refilling with water; has built-in test hydrometer
- Integral voltage regulator is built into Delcotron generators; is transistorized for greater reliability
- Starter solenoid is integral; provides positive starter engagement
- Distributor has integral coil; eliminates separate maintenance
- Large fuse block has tweezer-type fuse removal for easy serviceability
- Mufflers have heavy-gauge outer shell and are aluminized inside and out for added durability
- Engine coolant recovery system collects excess coolant in reservoir and returns it to radiator automatically when it cools
- No adjustment hydraulic clutch provided with manual transmission
- Tires have built-in tread wear indicators
- See-through reservoirs are used for quick checks of engine coolant, windshield washer fluid, and brake fluid
- No adjustments are needed for idle speed or idle mixture — an on-board computer tunes the engine as you drive
- Audible pad wear sensors on front disc brakes provide early warning of brake wear
- Front and rear brakes are self-adjusting
- Single-belt engine accessory drive with automatic belt tensioner never needs adjustment

## ACCIDENT AVOIDANCE FEATURES

- Separate front and rear brake systems with dual master cylinder and warning light
- Directional signal control with lane-change feature
- Four-way hazard-warning flasher
- Backup lights
- Side marker lights and reflectors
- Parking lamps that illuminate with headlamps
- Windshield defogger, washer and dual-speed wipers
- Large, below eyeline type outside left and right-hand rearview mirrors
- Inside rearview mirror with vinyl-bonded glass
- Starter safety switch
- Dual-action hood-latch system
- All Seasons tire tread design (highway-type tires)
- Tinted glass all-around
- Non-glare finish on wiper arms/blades and various front compartment components

## OCCUPANT PROTECTION FEATURES

- Lap/shoulder belts for driver and right front passenger, plus lap belts for

- all other seating positions; front out-board passenger seat belt includes provisions for accommodating child-restraint seat
- Seat belt reminder system
- Energy-absorbing steering column and wheel
- Energy-absorbing instrument panel
- Laminated safety windshield glass and tempered safety side and rear window glass
- Safety interlocking door latches
- Passenger-guard inside side door lock buttons and recessed door lock handles
- Inertia-locking seat backs
- Safety armrest
- Padded sun visors

## ANTI-THEFT FEATURES

- Audible reminder for ignition key removal
- Theft-deterrent ignition lock (also locks steering wheel and automatic transmission shift lever)
- Visible vehicle identification number
- Separate keys for ignition and door locks
- Inside hood release



GM's 6-year/100,000 km Powertrain Warranty and 6-year/160,000 km Corrosion Protection Warranty is included on every 1988 Light Duty Truck built in North America, including fleet vehicles. Your vehicle was designed and built to resist corrosion. Application of additional rust-inhibiting materials is not necessary or required under the 6-year/160,000 kilometre corrosion coverage. See your GMC Truck Dealer for limited terms and conditions.

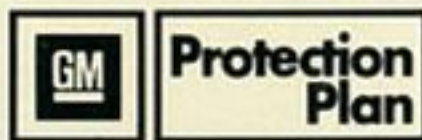

All new GM trucks come with a comprehensive GM New Vehicle Limited Warranty. And for those who desire even greater coverage during and after the limited warranty period, the GM Protection Plan is available. Plans are available that provide additional protection against the cost of many unexpected repairs for up to five years. It even offers allowances toward the cost of towing and procur-

ing a rental vehicle, if necessary. And unlike other extended repair protection plans, only GMPP is a direct agreement between General Motors and GM owners.

The list of GMPP benefits goes on, and your authorized GMC Truck Dealer will be pleased to provide complete details.

## GMAC

### FINANCING OR LEASING, IT'S AS EASY AS GMAC

The good feeling that comes when you buy or lease a new GM vehicle can be enhanced when it comes to making the financial arrangements. Which is why so many people finance with General Motors Acceptance Corporation. With GMAC it's done right in the showroom. Terms are tailor-made to suit your personal needs. You can choose your own monthly payment date. And the rates are friendly as can be.

So when the time comes, just tell us "I want GMAC". We'll take it from there while you relax.

## Join Us!



© COA 1979

### XV WINTER OLYMPICS CALGARY '88

General Motors of Canada is proud of our involvement with major events in Canada, from Expo '67 in Montreal to Expo '86 in Vancouver, from the 1976 Olympics to the Winter Olympics in Calgary in 1988.

General Motors is a sponsor and Official Supplier of Transportation to the XV Olympic Winter Games in Calgary in 1988. This world event will be a showcase for Canadian athletes, for all of Canada and all Canadians — a symbol of Canadian excellence.

At General Motors we are committed to excellence. And to Canada.

**GENERAL MOTORS TRUCKS**  
*The trucks more people lean on*



All illustrations and specifications contained in this catalogue are based on the latest product information available at time of publication approval. The right is reserved to make changes at any time, without notice, in prices, colours, materials, equipment, specifications and models, and to discontinue models. Some of the equipment shown or described throughout this catalogue is available at extra cost. Instrument cluster gauges and speedometers on Canadian-marketed Light Duty Trucks are displayed in metric units with appropriate international symbols. Check with your dealer for complete information.