

# 1976 Dodge Pickups.

For the man who'd rather  
drive a truck than a car.





# Dodge Conventional Cab

Built by the people who know what people want in a truck.

The Conventional Cabs are the most popular pickups built by Dodge. And that's because of know-how. It's the ability to design a pickup that gives a high payload capability. The offering of small but peppy standard Six and V8 engines with excellent EPA fuel economy ratings. These are solid, dollar-saving reasons why Dodge is a great pickup buy. Dodge also understands the need for a wide choice of equipment packages. The chart at right gives measurements and specifications for seven different models. Trim packages that personalize your purchase include the Adventurer SE, Adventurer Sport, Adventurer, and Custom. The lineup for interior and exterior color selections appears on pages eight and nine. And for rugged hauling, check out a full-time, four-wheel-drive model. Built from know-how. Maybe that's why the Conventional Cab gets the nod from the man who'd rather drive a truck than a car. Shown below: Dodge D100 Conventional Cab with Adventurer SE package and selected options.

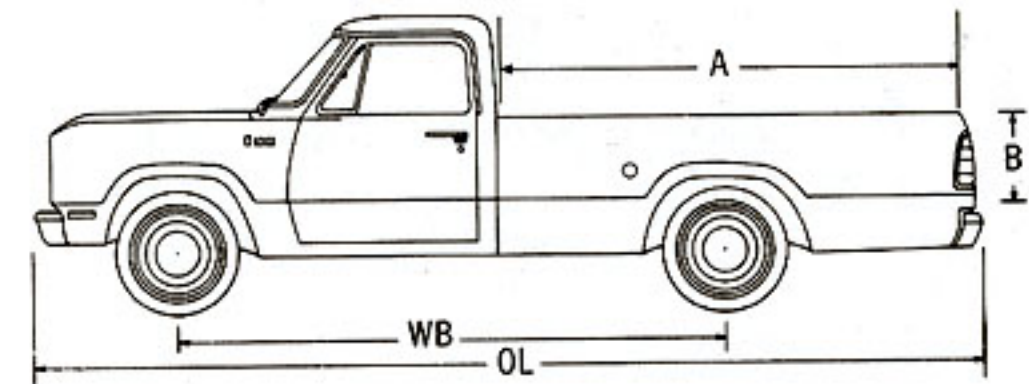

CONVENTIONAL CAB

MODEL	D100/W100	D100/W100	D200/W200	D300
Wheelbase (WB)	115"	131"	131"	131"
Overall length* (OL)	193.6"	213.6"	213.6"	213.6"
Overall width	79.5"	79.5"	79.5"	94.2"
Nominal inside length	6½'	8'	8'	8'
Inside length (A)	78"	98"	98"	98"
Inside width (max.)	70"	70"	70"	70"
Width between wheelhousings	51"	51"	51"	51"
Height—top of sides and tailgate (B)	19½"	19½"	19½"	19½"
Capacity (water level) cu. ft.	61.1	76.6	76.6	76.6

\*Including optional rear bumper.





# Dodge Club Cab

A "First" from Dodge and still out front for value.

When Dodge introduced the Club Cab, the idea was to provide extra storage inside. Now, there's 34 cubic feet of additional space—enough room for two optional jump seats that let you put five people in the cab. The idea caught on and has been widely imitated. But the Dodge Club Cab offers features you don't always find in the imitators. You can get a Club Cab in a full-time, four-wheel-drive model. The Club Cab has great maneuverability when the turns get tighter. And an exceptional load capacity of up to 5,544 pounds. These are out-front advantages. And you get them in a wide choice of models—check the chart at the right for measures and specs. You can get your pick of special trim packages, too. They include the Adventurer SE, Adventurer Sport, Adventurer, and the Custom. More information on exterior and interior trims appears on pages eight and nine. See what Dodge Club Cab has to offer. Then buy one and stay out front for value. Shown below: Dodge D100 Club Cab with Adventurer Sport package.

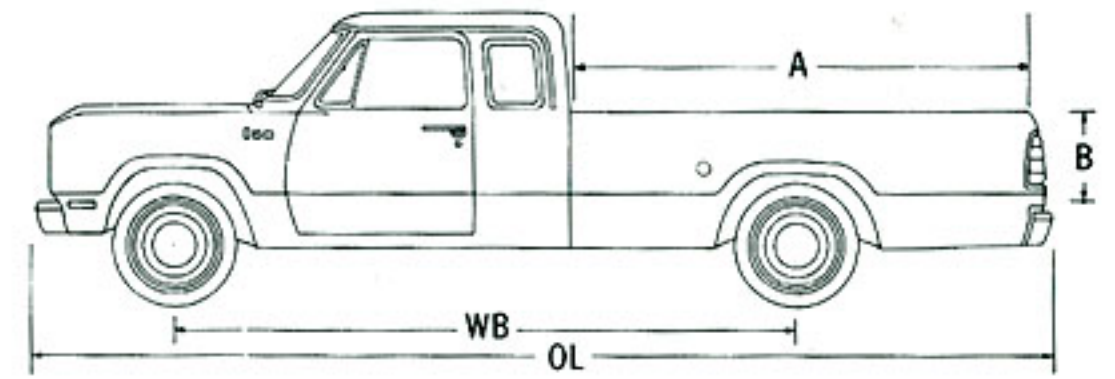

MODEL	CLUB CAB			
	D100/W100	D100/W100	D200/W200	D300
Wheelbase (WB)	133"	149"	149"	149"
Overall length* (OL)	211.6"	231.6"	231.6"	231.6"
Overall width	79.5"	79.5"	79.5"	94.2"
Nominal inside length	6½'	8'	8'	8'
Inside length (A)	78"	98"	98"	98"
Inside width (max.)	70"	70"	70"	70"
Width between wheelhousings	51"	51"	51"	51"
Height—top of sides and tailgate (B)	19⅝"	19⅝"	19⅝"	19⅝"
Capacity (water level) cu. ft.	61.1	76.6	76.6	76.6

\*Including optional rear bumper.





# Dodge Crew Cab

Seats six real grown-ups with a payload out back.

Owning a Dodge Crew Cab is like having a comfortable sedan out front of a full-capacity pickup. Four doors give easy, wide-open access to the passenger compartment's front and rear seats. Inside the Crew Cab, there are all kinds of legroom, headroom, and shoulder room. That's important when you're transporting six full-sized workmen to the job site. Out back, the Dodge-sized pickup box will bring along tools, power equipment, supplies, or whatever. This versatile pickup gives you Dodge dependability, too, in features such as an Electronic Ignition System that eliminates the need for points and condenser. The chart at the right gives a model run-down for Crew Cab availability. You can choose from two trim packages—the Adventurer and the Custom. For more exterior and interior trim information, see pages eight and nine. Pick the Crew Cab model you like best. You'll be getting seating for six and load capacity, too. Shown below: Dodge D200 Crew Cab with Custom package.

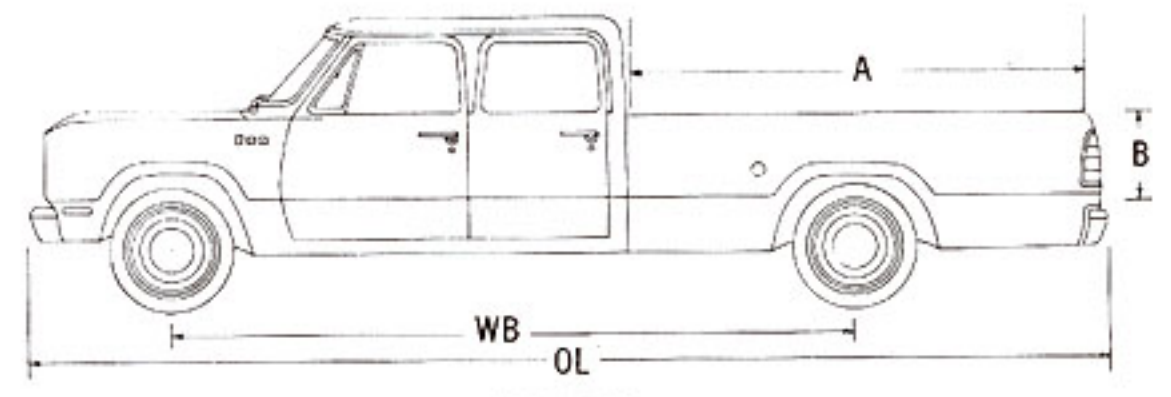

**CREW CAB**

MODEL	D200/W200	D200
Wheelbase (WB)	149"	165"
Overall length <sup>o</sup> (OL)	227.6"	247.6"
Overall width	79.5"	79.5"
Nominal inside length	6½'	8'
Inside length (A)	78.0"	98.0"
Inside width (max.)	70.0"	70.0"
Width between wheelhousings	51.0"	51.0"
Height—top of sides and tailgate (B)	19.12"	19.12"
Capacity (water level) cu. ft.	61.1	76.6

<sup>o</sup>Including optional rear bumper.

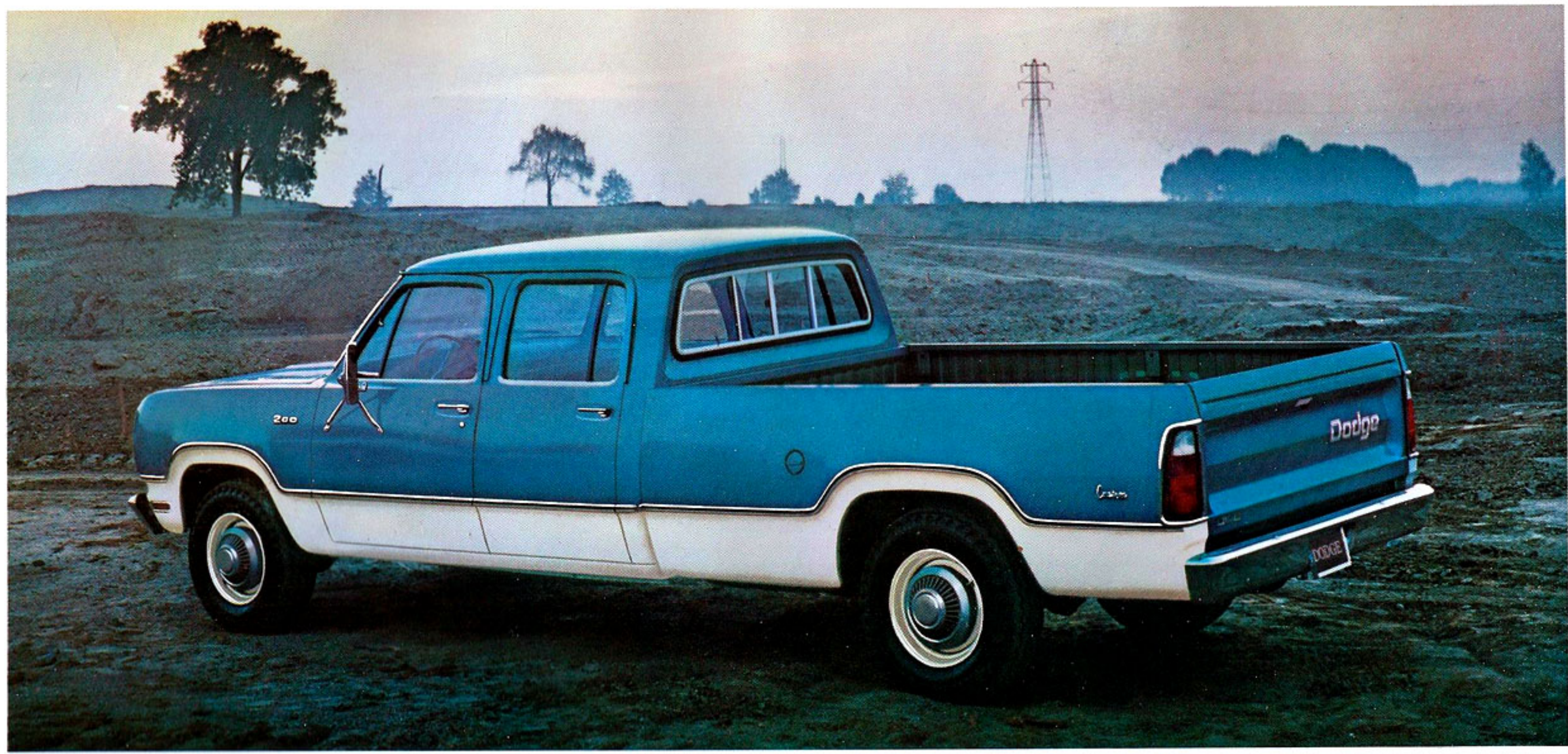



# Dodge Four-Wheel Drive Pickups

Three cab styles for those who tackle back roads and no roads.

When you're off in the boondocks and the wheels on your pickup start to slip on ice or mud or whatever, that's when you're glad you've got Dodge's full-time four-wheel drive. It provides deep-biting traction that digs in and pulls you through. There's no need to shift the front wheels or bother yourself with getting out to lock or unlock the front wheel hubs. Full-time four-wheel drive is there. It also provides great traction on ordinary wet or slippery roads. The four-wheel-drive system has five settings—High Lock, High, Neutral, Low, and Low Lock. Order the four-wheel-drive pickup of your choice: Conventional Cab, Club Cab, Crew Cab, Utiline, Sweptline, or light-duty stake. Trim package selections are the Adventurer SE, Adventurer Sport, Adventurer, Custom with Decorator package, and Custom. Pages eight and nine give further details on exteriors and interiors. For those bad roads and those no roads at all, get a full-time four-wheel-drive-equipped Dodge pickup.

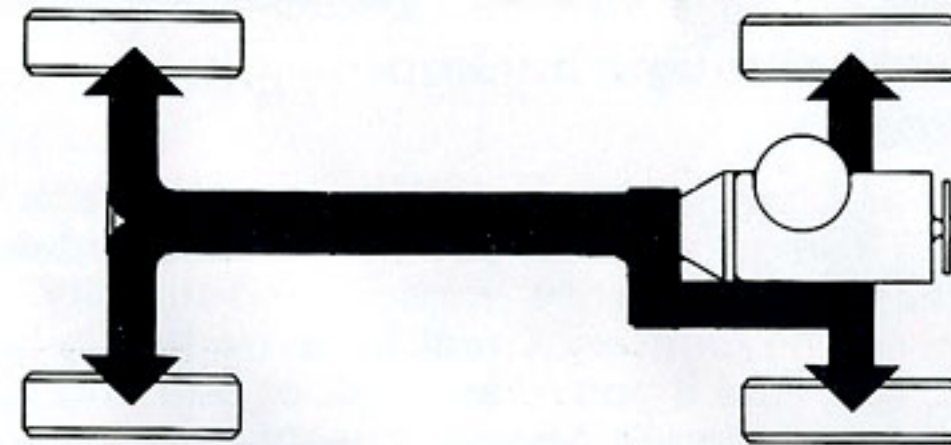

With Dodge full-time four-wheel drive, the driving power of four wheels is always there. An Inter-Axle Differential, located in the transfer case, adds to performance under varying conditions. For extra-tough, off-road hauling, it can be locked in . . . to provide equal power to both front and rear axles, which maximizes performance in ice, mud or snow.





# Dyna-Trac Dual Rear Wheels

For the pickup that needs backup on the back end.

The Dyna-Trac rear wheel option puts more muscle back there where you need it. You get a 6,900-pound rear axle and dual rear wheels that increase load capacity, traction, and stability. You'll want that on and off the highway. Great for extra-heavy loads around the farm, too. And if you're an outdoor buff and you're going to put a slide-on camper on your new pickup, think very hard about ordering the Dyna-Trac option. Model choices with Dyna-Trac include the D300 Conventional Cab with 131-inch wheelbase and the D300 Club Cab with 149-inch wheelbase. The chart at right gives you recommended driveline combinations for optimum hauling. Five trim packages are available: Adventurer SE, Adventurer Sport, Adventurer, Custom with Decorator package, and Custom. Repeat: If you know you're going to be hauling extra-heavy loads, give real consideration to Dyna-Trac.

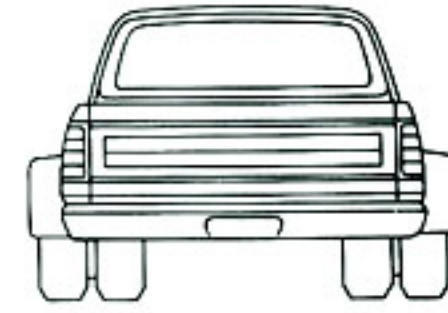
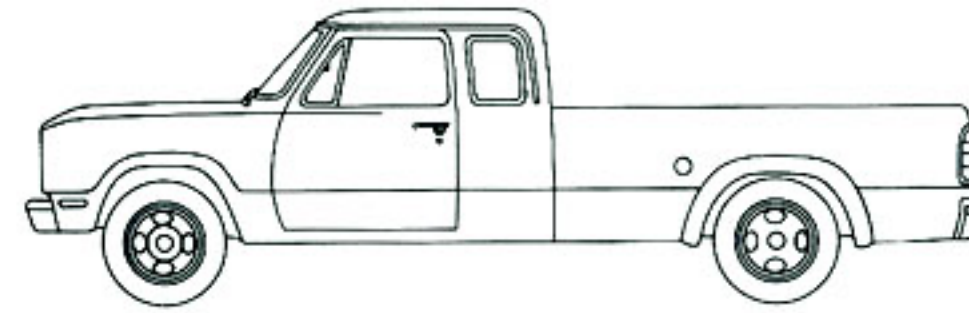

MODELS	WHEELBASES (in.)	GWWS (lbs.)
D300 Conv. Cab	131"	10,000
D300 Club Cab	149"	10,000





# Utiline Pickup

No fancy touches . . .  
just a tough truck.

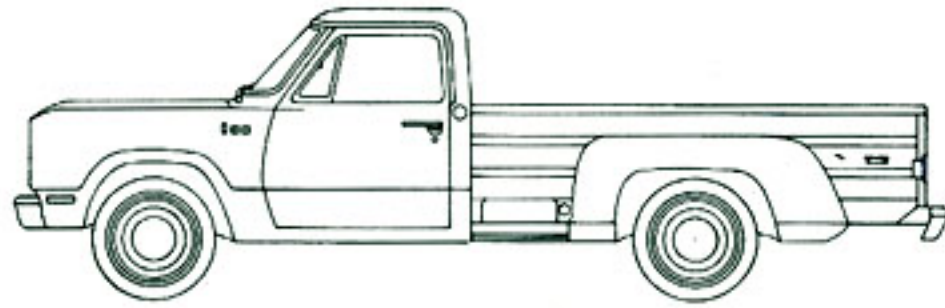

The name makes it clear: The Dodge Utiline is solidly built for all-around utility. And that includes a full measure of traditional Dodge pickup quality. A loyal following of owners also makes it clear they want a hard-working pickup that leaves out the frills. Note the running boards that help you get into the pickup bed for easier loading and unloading. Utiline comes in D100, D200, and W100 and W200 models with either the Adventurer or Custom trim package. Full-time, four-wheel-drive Utiline models are also available. See pages eight and nine for details on exterior and interior trim.



# Light-Duty Stake

Designed for loading  
and hauling a  
variety of cargo.

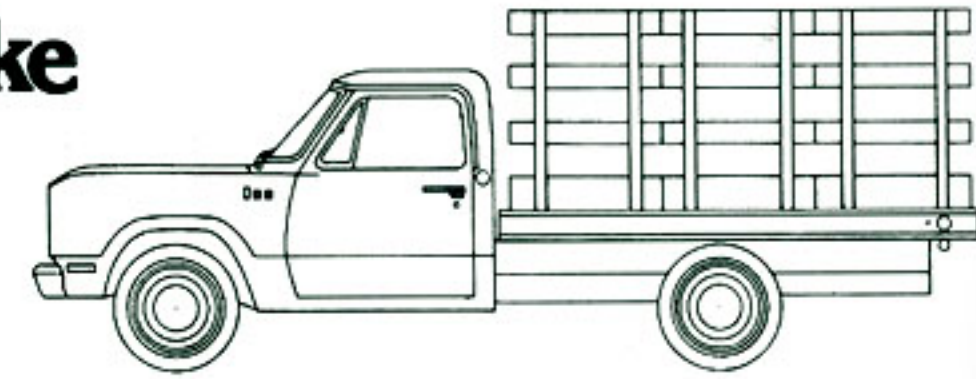

Dodge light-duty stakes let you handle a wide variety of cargo shapes and sizes. Put up all the stake sections and haul nursery and landscape stock. Remove the stake sections for cargo that calls for a flat bed. Use certain stake sections to load and haul odd-shaped cargo. Order the dual rear wheels, and the light-duty stakes can take on heavier loads. Model choices include the D200, D300, W200 and W300. Choose a handsome trim package from the Adventurer SE, Adventurer Sport, Adventurer, Custom with Decorator package and Custom. For more information on exteriors and interiors, see pages 8 and 9.





# Light-Duty Pickup Interiors

## Adventurer SE

More luxury than you'd ever expect in a truck. A hinged-back bench seat in Sweptline models with thick foam cushion and seat back. Pleated cloth-and-vinyl upholstery is color-keyed to interior color. Color choices include gold, blue, green, and black. In the Club Cab, a seat with spring and foam-pad topper with moulded full-foam in back.



## Decorator package

One more Dodge way to dress up a pickup to suit your taste. This one includes smart Boca Raton cloth-and-vinyl seat trim and color-keyed floor mat, with bright exterior drip moulding. Available with Custom Conventional pickup models... in a choice of colors that includes blue, green, parchment and gold.



## Adventurer Sport and Adventurer bench seat

Here's comfort combined with long wear. The full-width hinged-back seat in Sweptline models is covered with pleated vinyl with excellent wear quality. Seat cushion and seat back are full-foam. Color selection includes parchment, blue, green, black, and gold. Club Cab seat has a spring and foam-pad topper with moulded full-foam in back.





## Custom bench seat

Looks good, and it's durable, too. The full-depth foam cushion and seat back are covered with tough vinyl. Available with optional hinged seat back or fixed bench. The color selections include blue, green, parchment, and black. The Club Cab seat has a spring and foam-pad topper with moulded full-foam in back.

## Club Cab rear jump seats

You get an extra 34 cubic feet of space behind the Club Cab driver's seat, so that you can order two optional jump seats and make it a five-passenger cab.

## Conventional Cab bucket seats

Stylish as well as comfortable, with all-vinyl upholstery in a choice of parchment or black. Also included are a center console, carpeting, and insulation. Available in D100, D200, and D300 Conventional Cab models.

## Club Cab bucket seats

Here's the luxury of deluxe bucket seats, upholstered in durable vinyl. An insulated storage chest between the seats keeps your refreshments as you like them. Passenger seat tilts forward for easy access to the rear compartment. Available in D100, D200, D300, W100, and W200 Club Cab models.

## Interior and exterior features:

### Adventurer SE Features:

Along with the Custom model features, the following items are included when you order the Adventurer SE package:

- Exterior body side mouldings with wood-grained vinyl inserts along fender, door, and body
- Side nameplate "Adventurer SE"
- Tailgate mouldings with wood-grained vinyl insert and nameplate (Sweptline pickup models only)
- Bright and simulated wood-grained instrument panel trim moulding
- Cloth-and-vinyl full-foam seats and back, color-keyed. Hinged-back bench seat in Conventional Cab with Sweptline pickup
- Inner door trim panels—plastic with wood-grained applique and integral armrests, and vinyl lower door storage pockets
- Bright tread plates
- Bright trim around accelerator, brake and clutch pedals
- Carpeting, color-keyed
- Convenience package
- Formed plastic rear side and back inner panels on Club Cab.

### Plus:

- Bright grille
- Bright front bumper
- Bright vent wing division bar
- Bright drip rails, rear window mouldings, side quarter window mouldings (Club Cab), and windshield mouldings
- Bright tail lamp bezels (Sweptline pickup models)
- Bright and simulated wood-grained instrument face plate
- Parchment-colored foam core headliner
- Cigarette lighter
- Horn bar
- Bright hubcaps (not available with dual rear wheels)
- Color-keyed instrument panel with SE nameplate
- Bright front wheel-lip mouldings (all models) and bright rear wheel-lip mouldings on Sweptline models.

### Adventurer Sport Features:

Along with the standard Custom model features, the following items are included when you order the Adventurer Sport package:

- Exterior paint-filled wide body side mouldings
- Side nameplate "Adventurer Sport"
- Bright paint-filled tailgate mouldings (Sweptline pickups only)
- Bright and simulated wood-grained instrument panel trim moulding
- Bright and simulated wood-grained instrument cluster face plate
- Pleated vinyl seats with buttons and full-foam cushion and seat back, color-keyed. Hinged-back bench seat in Conventional Cab with Sweptline pickup
- Inner door trim panels with integral armrests and simulated wood-grained applique
- Bright front wheel-lip mouldings (all models) and bright rear wheel-lip mouldings on Sweptline models.

### Plus:

- Bright grille
- Bright front bumper
- Bright vent wing division bar
- Bright drip rails and bright windshield and rear window mouldings
- Bright tail lamp bezels (Sweptline pickup models)
- Bright side window mouldings (Club Cab only)
- Parchment-colored foam core headliner
- Cigarette lighter
- Horn bar
- Bright hubcaps (except with dual rear wheels)
- Adventurer Sport nameplate on instrument panel
- Deluxe front floor mat, color-keyed
- Formed plastic rear side and back inner trim panels—color-keyed (Club Cab only).

### Adventurer Features:

Along with the standard Custom model features, the following items are included

when you order the Adventurer package:

- Exterior body side mouldings along fender, door, and Sweptline box
- Side nameplate "Adventurer"
- Tailgate mouldings, upper and lower (Sweptline only)
- Pleated vinyl seats with buttons and pad, color-keyed. Hinged-back bench seat in Conventional Cab with Utiline or Sweptline pickup
- Inner door trim panels—fiber-glass with integral armrests, color-keyed with bright mouldings, and Adventurer nameplate on instrument panel
- Instrument panel moulding.

### Plus:

- Bright grille
- Bright front bumper
- Bright vent wing division bar
- Bright windshield moulding
- Bright tail lamp bezels (Sweptline pickup only)
- Cigarette lighter
- Horn bar
- Deluxe front floor mat, color-keyed
- Formed plastic rear side and back inner trim panels on Club Cab.

### Custom Features:

The following items are included when you order the Custom model:

- Side nameplate "Custom" on Sweptline box
- Vinyl seats with full-depth foam cushion
- D100, D200, D300, W100, or W200 nameplate on front fender
- Color-keyed padded instrument panel
- Color-keyed seat trim
- Color-keyed armrests.

### Plus:

- Bright grille
- Bright front bumper
- Painted hubcaps
- Horn button
- Black rubber floor mat
- 10-inch inside day/night rearview mirror
- Padded sun visors
- Bright mirrors.

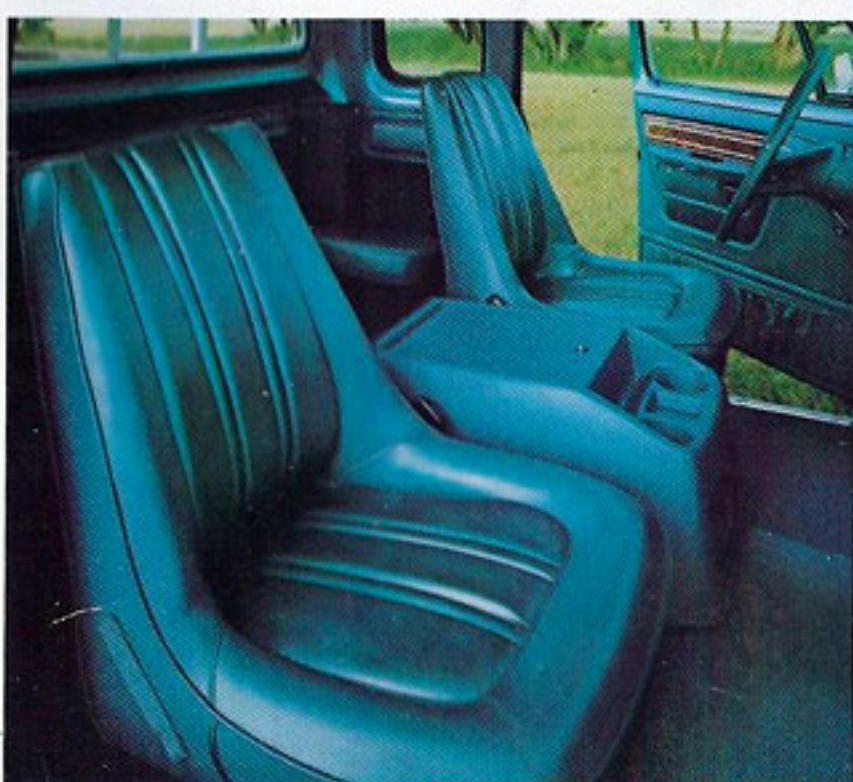



# Comfort, Convenience and Durability Features for 1976 Dodge Pickups

**One-hand tailgate operation**  
All Dodge Sweptline models have the easy-off tailgate that can be removed without tools. Tailgate release is located high on the tailgate, making it simple to release the latch and lower the tailgate with one hand.



**Double-wall construction**  
Something Dodge has been putting into all pickups for many years. Double-wall construction adds greatly to strength, durability, and overall value.



**Gas tank located outside cab**  
Depending on the wheelbase, an 18- or a 20-gallon fuel tank is located outside of the cab. Two fuel fillers are provided on models equipped with main and auxiliary fuel tanks.



**Antispin differential**  
Adds to dependable Dodge pickup performance; helps get you through tough mud or snow conditions.

Dodge D100 Conventional pickup, with selected optional equipment.



**Independent front suspension (D models only)**  
A smooth-riding suspension that assures passenger and driver an even, comfortable ride. Front springs are specially designed and selected for individual truck needs. Heavy-duty springs are standard on higher GVW packages.

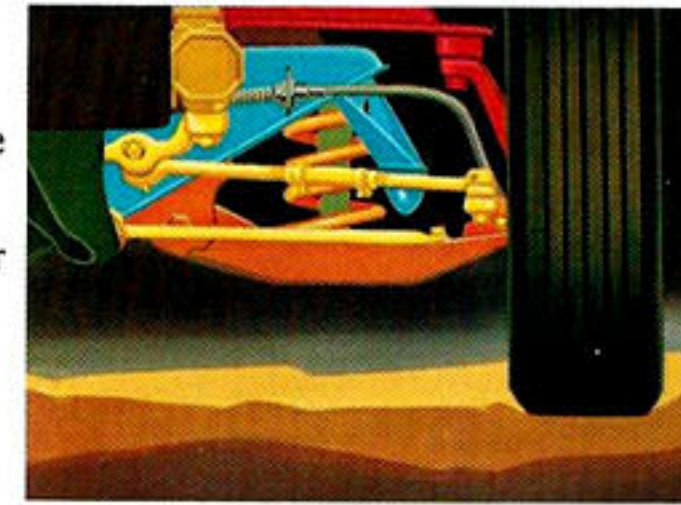

**Heavy-duty alternator**  
Available in either 52 or 63 amps. When air conditioning and trailer-towing packages are ordered, the 52-amp alternator is included.

**Exceptional rust protection**  
During assembly operations, a special phosphate coating is applied. Special primers are also added. Zinc-rich paint is used in hidden and hard-to-reach areas to protect against the effects of road splash, condensation, and water accumulation. Drains protect areas where water might become trapped. Cab seams and openings are doubly protected by a vinyl sealer.



Phosphate bath during Dodge assembly.



High-pressure primer spray.



**Front disc brakes**  
An extra measure of stopping power on demand. Powerful fade-resistant front disc brakes are standard equipment on all Dodge pickups. The rear brakes are sturdy drum-type.



# Selected standard and optional equipment for 1976 Dodge Pickups

## Dodge engines—the heart of a pickup.

No truck engines are more highly regarded than the 225 Slant Six and the Dodge 318 V8. Both are standard power plants for the D100, D200, D300, W100 and W200 pickup models. Both have logged many millions of in-use miles, giving dependable service and honest operating economy. For heavy-duty use such as hauling a slide-on camper, it's recommended that owners order one of the bigger optional V8s. These choices include the 360-, 400-, and the 440-cubic-inch V8s, depending on the model.

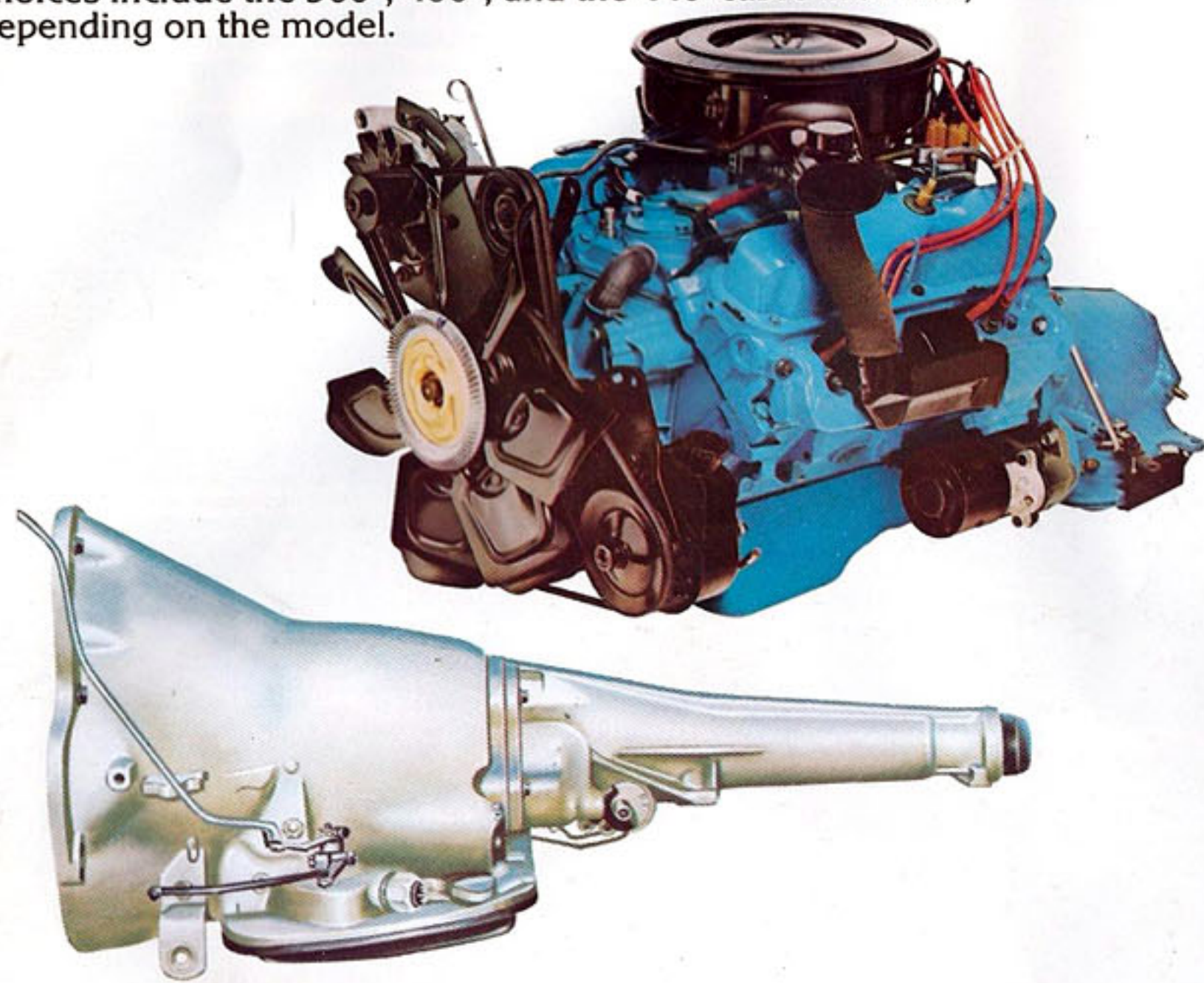

## Transmissions—engineered to suit the job.

Dodge's dependable three-speed manuals have a reputation for staying on the road and out of the shop. They're standard for the D100, D200, W100, and W200 pickup models. For more rugged duty such as camper hauling and heavy city traffic, it is suggested that owners order the optional four-speed manual or the optional LoadFlite three-speed automatic transmission. The four-speed manual is standard on the D300 and W300. All are Chrysler-engineered for power to suit the job.

**Wood-grained-finish instrument panel** has a full complement of easy-to-read dials and gauges. Special items such as tachometer, clock, vacuum gauge, and voltmeter are also available as options.



**Fuses and flasher units** are conveniently located in the glove box within easy reach.



**Electronic Ignition** eliminates points and condensers that can wear out or get wet. Gives up to 35% more starting voltage than conventional ignition systems, and up to 30,000 miles of spark plug life with unleaded fuel.

**Tool box** under cargo box keeps equipment under lock and key.

**Automatic speed control** holds speed to chosen setting. Optional.

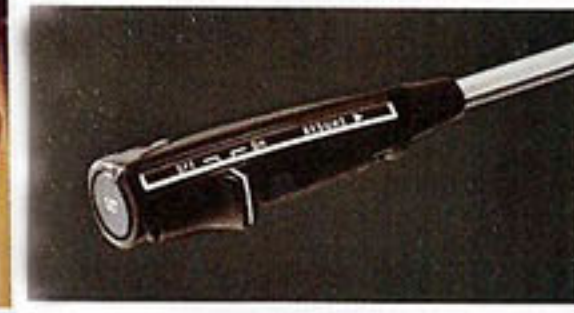

**Factory-installed air conditioning** keeps the cab comfortable for long hauls in high heat. Optional.

**New glide-out spare tire option** for '76 gives more convenient access to the spare, lessens the work of tire changes.



**Wraparound taillights** are recessed to protect against breakage, can be easily seen from sides and rear.



**Side marker lights** can be seen easily at night, add to safe hauling.



**LoadFlite automatic transmission** provides power with smooth shifting in or out of heavy traffic. Optional.

**Stylish bumper guards** (Protection package) provide added protection for the front end. Optional.



**In-cab hood release** protects your engine from tampering wherever you are. Optional.



**Stylish box rails** dress up the appearance of your Dodge pickup.



**Premium wheel covers** add an elegant touch. Optional.

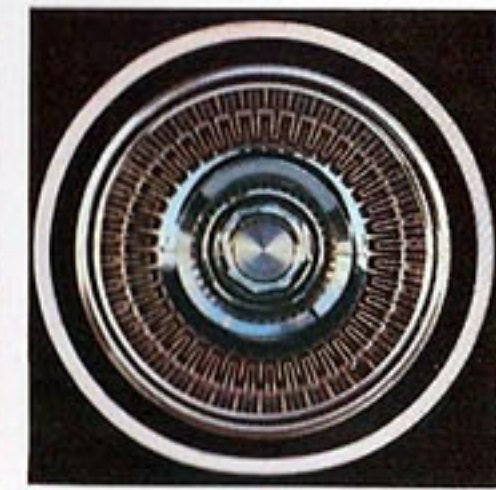

**Sporty road wheels** are bright-finish. Optional.



**Order a rear sliding window** for extra ventilation and better access to the cargo box. And a cargo light above the window that adds to ease of loading, or unloading, at night.



**AM/FM radio option**, another reason why long days at the wheel will pass more pleasantly in a Dodge pickup.





# Four-Wheel Drive Specifications

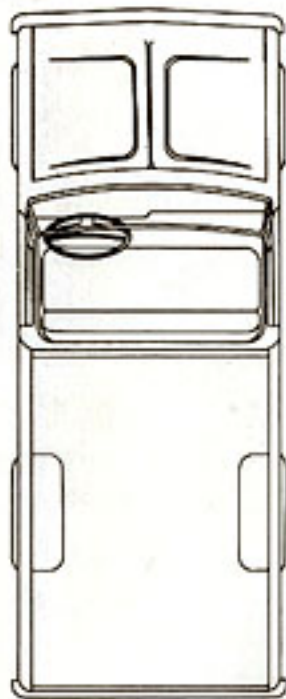

Wide choice of seating:  
Three-passenger seating in Conventional Cabs.

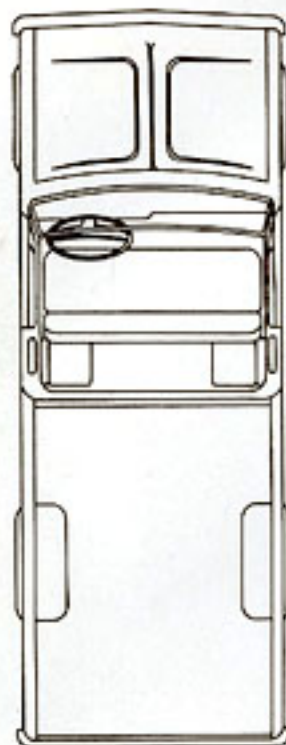

Five-passenger seating in Club Cabs.



Six-passenger seating in Crew Cabs.

SPECIFICATIONS	W100	W200	W300	W600
ENGINES—6-CYL. —V8	225-1			
	318-1, 360 (h), 400, 440	318-1, 360 (h), 400, 440	381-1, 360 (h), 400, 440	318 PREMIUM, 360-3
CLUTCH—DIAMETER —AREA	11" 123.7 SQ. IN.			
TRANSMISSION	3-SPD. SYN. 4-SPD. SYN. (NP435) (b) 4-SPD. SYN. (NP445) (c) 3-SPD. AUTOMATIC (A727)		4-SPD. SYN. (NP435) (b) 4-SPD. SYN. (NP445) (c) 3-SPD. AUTOMATIC (A727)	4-SPD. SYN. (NP435) 5-SPD. SYN. (NP540)
TRANSFER CASE	FULL-TIME FOUR-WHEEL DRIVE, SINGLE-LEVER			2-SPEED, 2-LEVER
AXLE, FRONT—CAPACITY	3,500 LBS. 4,000 LBS.	3,500 LBS. 4,000 LBS. (f), 4,500 LBS.	4,500 LBS.	6,000 LBS., 7,500 LBS.
AXLE, REAR—CAPACITY RATIOS	3,600 LBS. 3.2, 3.9, 3.55 (225, 318, 360, 400) 3.2, 3.55 (440)	5,500 LBS. 4.10	7,500 LBS. 4.88	15,000 LBS., 17,500 LBS. (g) 6.2, 6.8 6.8
SPRINGS, FRONT CAPACITY (AT GROUND)	1,640 LBS. 1,800 LBS., 2,100 LBS. (f)	1,640 LBS., 131" WB 1,800 LBS., 131" WB 1,800 LBS., 149" WB 2,250 LBS. ALL WB	1,940 LBS. 2,250 LBS.	3,000 LBS. 3,750 LBS.
SPRINGS, REAR CAPACITY (GROUND)	1,520 LBS., 115", 131" WB 1,820 LBS., STD. 133" & 149" WB OPT. 115" & 131" WB	2,175 LBS. 2,725 LBS.	2,820 LBS. 3,650 LBS.	7,500 LBS., 8,500 LBS. 9,250 LBS.
				8,500 LBS., 9,250 LBS. 10,400 LBS.
			585 LBS.	2,300 LBS.
AUXILIARY REAR SPRING				
TIRES—FRONT & SINGLE REAR	G78-15-B (4PR.) (8 CYL.) 115" WB 131" WB	8.00-16.5-D (8PR.)	8.75-16.5-E (10PR.)	
—FRONT & DUAL REAR	H78-15-B (4PR.) (ALL OTHER)			8.25-20-E (10PR.)
MAX. AVAIL.—FRONT & SINGLE REAR	7.00-15-D (8PR.) (f)	9.50-16.5-E (10PR.)	9.50-16.5-E (10PR.) 7.50-16-D (8PR.)	9.00-20-F (12PR.)
—FRONT & DUAL REAR				
BRAKES, SERVICE	HYDRAULIC DUAL BRAKING SYSTEM WITH WARNING LIGHT			SINGLE HYDRAULIC SPLIT-BRAKING SYSTEM
FRONT BRAKE SIZE (IN.)	11.75" x 1.25" DISC	12.82" x 1.19" DISC	12.88" x 1.19" DISC	14" x 2.25"—122.4
REAR BRAKE SIZE (IN.)—AREA (SQ. IN.)	11" x 2.5"—106.4	12" x 2.5"—122.8	12" x 3.0"—147.4	15" x 5"—316.0,
BRAKES, VACUUM POWER	9.0" DIAMETER	9.0" DIAMETER	9.0" DIAMETER	11.5" DIAMETER, TWO 12.8"
OTHER COMPONENTS				
AIR CLEANER	DRY-TYPE	1-QT. OIL BATH		DRY-TYPE
ALTERNATOR	12-VOLT, 48-AMP, 52-AMP, OR 63-AMP			
BATTERY	12-VOLT, 48-AMP-HR 59-AMP-HR, 70-AMP-HR			12-VOLT, 59-AMP-HR 70-AMP-HR OR 90-AMP-HR
BRAKES, PARKING SIZE	11" x 2.5"	FOOT PEDAL TYPE 12" x 2.5"	12" x 3"	HAND LEVER 10" x 1.5"
FRAME—SECTION MODULUS MATERIAL P.S.I.—AVERAGE	3.43—115" WB, 3.88—131" WB 4.75—133" WB (d) 5.47—149" WB (d) 36,000	3.88—131" WB, 5.02—149" WB (a) 5.47—149" WB (d) 36,000	5.02 36,000	14.5 (e) 50,000

- (a) CREW CAB.
- (b) WIDE-SPACED RATIO.
- (c) CLOSE-SPACED RATIO.
- (d) CLUB CAB.
- (e) WITH REINFORCEMENT.
- (f) WITH SNO-FILTER PACKAGE ONLY.
- (g) INCLUDES 15" x 6" BRAKES.
- (h) AVAILABLE IN STATE OF CALIFORNIA ONLY.

EQUIPMENT IN RED—OPTIONAL AT EXTRA COST.  
All models include Electronic Ignition and Evaporative and Exhaust Emission Control Systems.  
NOTE: Optional Emission Reduction Control System is required on all models registered in the state of California.

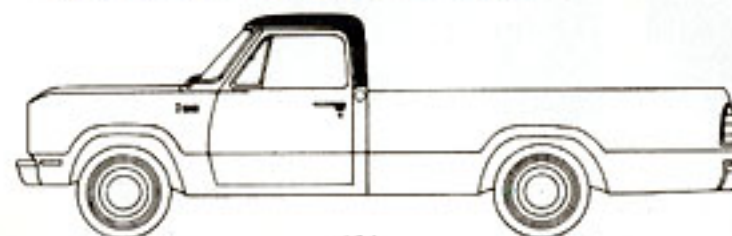

(1)



(2)



(3)

## Two-tone paint options

There are three two-tone paint options on Dodge pickups for 1975. (1) On all models, you can get the main color from the cab window sill down, a secondary color from this line up. (2) On Sweptline models only, you can get the main color on top, the secondary color on the bottom. (3) On Sweptline models only, you can get the main color in the middle with the secondary color on top and bottom.



# Light-Duty Pickup Specifications

SPECIFICATIONS	D100			D200		D300	
ENGINES—6-CYL. —V8				225-1 318, 360 (i), 400, 440			
CLUTCH—DIAMETER —AREA —DIAMETER —AREA	10" (6-CYL.) 100.6 SQ. IN.	11" (6-CYL.) 123.7 SQ. IN.	11" (V8) 123.7 SQ. IN.	11" 123.7 SQ. IN. 12" (400 V8) 150 SQ. IN.	11" (6-CYL.; 318 V8) 123.7 SQ. IN. 12" (400 V8) 150 SQ. IN.		
TRANSMISSION	3-SPD. SYN. 4-SPD. SYN. (NP435) 4-SPD. SYN. (NP445) 3-SPD. AUTOMATIC (A727)			3-SPD. SYN. 131", 149" WB 4-SPD. SYN. (NP435), 165" WB 4-SPD. SYN. (NP435) 4-SPD. SYN. (NP445) 3-SPD. AUTOMATIC (A727)		4-SPD. SYN. (NP435) 4-SPD. SYN. (NP445) 3-SPD. AUTOMATIC (A727)	
AXLE, FRONT—CAPACITY	3,000 LBS.			3,300 LBS., 131", 149" WB 3,800 LBS., 165" WB		3,800 LBS.	
AXLE, REAR—CAPACITY	3,300 LBS.			5,500 LBS., 131", 149" WB; 6,200 LBS., 165" WB		7,500 LBS., 135", 159", 165" WB 6,900 LBS., 131", 149" WB 4.56, 4.1, 4.8	
RATIOS	3.2 (a), 3.55 (a), 3.9 (a)—6-CYL.; 2.71, 3.2(a), 3.55(a), 3.9(a)—V8			3.54, 4.1		4.1	
SPRINGS, FRONT CAPACITY (AT GROUND)	1,340 LBS., 6-CYL., 115" WB 1,440 LBS., 6-CYL., 115" WB 1,440 LBS., 8-CYL., 115" WB 1,540 LBS., 8-CYL., 115" WB (d) 1,440 LBS., 6-CYL., 131", 133", 149" WB 1,540 LBS., 6-CYL., 131", 133", 149" WB 1,540 LBS., 8-CYL., 131", 133", 149" WB 1,615 LBS., 8-CYL., 131", 133", 149" WB (d)			1,465 LBS. 6-CYL., 131", 149" CLUB CAB WB 1,645 LBS., 6-CYL., 149" CREW CAB WB 1,915 LBS., 6-CYL., 165" WB 1,565 LBS., V8, 131", 149" CLUB CAB WB 1,645 LBS., V8, 149" CREW CAB WB 1,915 LBS., V8, 165" WB 1,565 LBS., 6-CYL., 131", 149" CLUB CAB WB 1,645 LBS., 6-CYL. & V8, 131", 149" CLUB CAB WB 1,715 LBS., 149" 6 & 8-CYL. CREW CAB WB 1,915 LBS., 165" WB V8, 131" & 149" CLUB CAB WB		1,540 LBS. 135" WB 1,690 LBS., 131", 149", 159" WB 1,915 LBS., 165" WB	
SPRINGS—REAR CAPACITY (AT GROUND)	1,520 LBS., ALL WB			2,175 LBS. 131" & 149" WB 2,820 LBS., 165" WB		2,820 LBS., 135" & 159" WB WITH SING. REAR WHL. 3,650 LBS., 131", 135", 149" & 159" WB (d) WITH DUAL REAR WHL. 2,900 LBS., 165" WB 3,650 LBS., 135" & 159" WB (d) WITH SING. REAR WHL. 3,650 LBS., 165" WB (d)	
MAXIMUM AVAILABLE	1,820 LBS., ALL WB			2,725 LBS., 131" 149" WB 585 LBS. AUX., 131", 149" CLUB CAB, 165" WB			
TIRES—FRONT AND SINGLE REAR —FRONT AND DUAL REAR	G78-15-B (4PR)			8.00-16.5-D (8PR).		8.00-16.5-D (8PR.) 135" & 159" WB 8.00-16.5-C (6PR.) FRT. 131" & 149" WB 8.00-16.5-D (8PR.) REAR 131" & 149" WB SWEPTLINE PICKUP ONLY. 8.00-16.5-E (10PR.) REAR 149" WB CHASSIS CLUB CAB ONLY. 8.00-16.5-C (6PR.) 165" WB 9.50-16.5-E (10PR.) 8.00-16.5-E (10PR.)	
MAX. AVAIL.—FRONT AND SINGLE REAR —FRONT AND DUAL REAR	LR78-15-B (4PR.) (e)			9.50-16.5-E (10PR.)			
BRAKES, SERVICE	HYDRAULIC DUAL BRAKING SYSTEM WITH WARNING LIGHT						
FRONT—FRONT AXLE CAPACITY DISC BRAKE SIZE (IN.)— AREA (SQ. IN.) (PAIR) REAR—REAR AXLE CAPACITY DRUM BRAKE SIZE (IN.)— AREA (SQ. IN.) (EACH)	3,000 LBS. 11.75 X 1.25—218.5 3,300 LBS.		3,300 LBS. 5,500 LBS.		3,800 LBS. 6,200 LBS.		3,800 LBS. 7,500 LBS. 6,900 LBS.
	10 X 2.5—97.6		12.12 X 2—104.7 12 X 2.5—122.8		12 X 3—147.4		12 X 3—147.4
BRAKES, VACUUM POWER	11" DIAMETER			9" DIAMETER (DUAL DIAPHRAGM)			
AIR CLEANER	DRY-TYPE (6-CYL. AND V8)			DRY-TYPE (6-CYL. AND V8) 1-QT. OIL BATH (6-CYL. AND 318 V8)		1-QT. OIL BATH (6-CYL.) (V8) (f) DRY-TYPE (V8)	
ALTERNATOR	12-VOLT, 48-AMP, 52-AMP OR 63-AMP						
BATTERY	12-VOLT, 48-AMP-HR, 59-AMP-HR (g), 70-AMP-HR (h)						
BRAKES, PARKING	FOOT PEDAL TYPE						
SIZE	10" X 2.5"		12.12" X 2"		12" X 2.5"		12" X 3"
SHOCK ABSORBERS	FRONT AND REAR, HEAVY-DUTY			FRONT AND REAR, HEAVY-DUTY		FRONT OR FRONT & REAR, HEAVY-DUTY	
STEERING	RECIRCULATING BALL MANUAL, POWER STEERING						

- (a) ANTISPIN DIFFERENTIAL AVAILABLE WITH 3.2, 3.55 AND 3.9 REAR AXLE RATIOS.  
(b) CLUB CAB.  
(c) CREW CAB.  
(d) MINIMUM SPRINGS WITH A/C.  
(e) WSW STEEL-BELTED RADIAL.  
(f) 318 V8.  
(g) INCLUDED WITH 360 AND 400 V8 ENGINES.  
(h) INCLUDED WITH 440 V8 ENGINE.  
(i) AVAILABLE IN THE STATE OF CALIFORNIA ONLY.  
NOTE: OPTIONAL EMISSION REDUCTION CONTROL SYSTEM IS REQUIRED ON ALL MODELS REGISTERED IN THE STATE OF CALIFORNIA.

Equipment in red—optional at extra cost.  
All models include Electronic Ignition System.  
All D100 models include Evaporative and Exhaust Emission Control System or Heavy-Duty Exhaust Emission Control System.  
All D200 and D300 models include Heavy-Duty Exhaust Emission Control System.  
N.A.D. (Non-Aqueous Dispersion) Acrylic Enamel is the finish for Dodge pickup models. It was selected because of its durability and resistance to fading, nicks, and abrasion.  
NOTE: Due to occasional printing irregularities, the colors shown may vary slightly from actual hues. See your Dodge Dealer for accurate color chips.

## Exterior colors



\*This color is an extra-cost paint on all models.





## Dodge trailer-towing and RV packages.

Dodge light-duty pickups make excellent trailer-towing and slide-on-camper-carrying vehicles. All have coil spring front suspension and durable leaf springs for passenger-car driving comfort. Your Dodge Dealer will be happy to give you a Dodge Trailer-Towing and Recreational Vehicle catalog and assist you in selecting the right pickup and equipment to do the job.



**Dodge**

**Dodge Trucks**



**YOUR SIGNS FOR  
MOTORING SATISFACTION**



All product illustrations and specifications are based on authorized information. Although all descriptions are believed correct at publication approval, accuracy cannot be guaranteed. Some of the equipment shown on product illustrations is optional at extra cost. Dodge reserves the right to make changes from time to time, without notice or obligation, in prices, specifications, colors and materials and to change or discontinue models.

Form No. 81-305-6123

Litho in U.S.A. 9/75